

**CX EXCAVATOR**

# **CX EXCAVATOR**

## **Service Training Manual**

**#5087** REV. 2001

# **CX SERIES EXCAVATORS**

## **Service Training Manual**

### **Table of Contents**

**Section 1** ..... General Introduction

**Section 2** ..... Component Locations - Hydraulics / Electrical

**Section 3** ..... Controller

**Section 4** ..... Electrical – “How it Works”

**Section 5** ..... Hydraulic – CX130/CX160 “How it Works”

**Section 6** ..... Hydraulic – CX210/CX240 “How it Works”

**Section 7** ..... Pressure Data

**Section 8** ..... Engine Electronic Fuel System

**Section 9** ..... Schematics

# **CASE**

**Construction Equipment Service Training**

# **CX SERIES EXCAVATOR**



## **Section 1 -- GENERAL INTRODUCTION**

(2001)

**Training  
Pays**

**CASE CORPORATION**  
700 STATE STREET  
RACINE, WI 53404 U.S.A.

**CASE CANADA CORPORATION**  
3350 SOUTH SERVICE ROAD  
BURLINGTON, ON L7N 3M6 CANADA

© 2001 Case Corporation  
All Rights Reserved

Printed in U.S.A.

# TABLE OF CONTENTS

## Section 1 - General Introduction

	PAGE NO.
Engines .....	2
Reservoir .....	3
Filters .....	3
Pumps .....	4
Pilot System .....	6
Hydraulic Systems .....	6-7
Cushion Control .....	7
Swing .....	7
Travel .....	8
Cylinders .....	9
Electrical System.....	10-11

## GENERAL INTRODUCTION

---

### EXPLANATION OF CX SERIES

<b>Engines</b>				
<b>MODEL</b>	<b>CX130</b>	<b>CX160</b>	<b>CX210</b>	<b>CX240</b>
<b>Make</b>	CASE	CASE	CASE	CASE
<b>Model</b>	4TA390	4TA390	6TAA590	6TAA590
<b>HP (net)</b>	106	106	138	163
<b>Cold Start</b>	Ether	Ether	Electric	Electric
<b>Rated rpm</b>	2200	2200	1950	2150

When programming the machines, the manufacture model number must be used. Detailed procedures are in section 7 of your service manual.

<b>Manufacture model number</b>	<b>Case model number</b>
SHO120	CX130
SHO150	CX160
SHO200	CX210
SHO220	CX240

When programming the machines, the following codes will be used to change the language if necessary. Detailed procedures are in section 7 of your service manual.

<b>LANGUAGE</b>	<b>MODE NO.</b>	<b>LANGUAGE</b>	<b>MODE NO.</b>	<b>LANGUAGE</b>	<b>MODE NO.</b>
Japanese	0	Italian	6	Swedish	12
English	1	Spanish	7	Finnish	13
Thai	2	Portuguese	8	Picture writing	14
Chinese	3	Dutch	9		
German	4	Danish	10		
French	5	Norwegian	11		

## GENERAL INTRODUCTION

---

### EXPLANATION OF CX SERIES

#### Reservoir

The reservoir is pressurized on all models. The air charge is provided by thermal expansion and the differential area of the cylinders as they are stroked the first time. There is a breather/pressure regulator/fill cap installed in the top cover of the units. A rubber-covered button on top of the breather is provided to release the air pressure in the reservoir. A sight gauge mounted to the side of the reservoir indicates the oil level. There is a 150-mesh screen at the outlet of the reservoir to the hydraulic pump.

Reservoir				
MODEL	CX130	CX160	CX210	CX240
Capacity Tank gal.	19	32	32	32
Capacity System gal.	32	38	54	59

#### Filters

The oil returning from the main control valve flows through the oil cooler. There is a cooler bypass valve in the circuit to protect the system during cold start conditions. As the oil returns from the oil cooler, it passes through a full flow 10-micron filter. Some of the return oil is routed through a 1-micron ultra-fine filter. Drain oil from the pilot control circuits and the case drain oil from the swing and travel motors is returned through the main return filter.

A cartridge type filter is installed in the outlet of the pilot pump to protect all pilot valves from contamination. All of these filters have filter bypass valves for cold start up protection.

Filters				
MODEL	CX130	CX160	CX210	CX240
Suction	150 mesh	150 mesh	150 mesh	150 mesh
Return	10 $\mu$	10 $\mu$	10 $\mu$	10 $\mu$
Ultra-fine	1 $\mu$	1 $\mu$	1 $\mu$	1 $\mu$
Pilot	10 $\mu$	10 $\mu$	10 $\mu$	10 $\mu$

# GENERAL INTRODUCTION

---

## EXPLANATION OF CX SERIES

### Variable Pumps

All of the CX Series Excavators use an open center hydraulic system, in that there is always an output flow from the hydraulic pump flowing through the system. The CX Series Excavators use a variable volume piston pump system to be able to fully use the engine horsepower available. As the system operating pressure increases, the flow gradually reduces, to maintain a constant horsepower load on the engine. The theory is that when very high pressures are required, speed isn't so important. The CX Series Excavators use a two-section variable displacement piston pump, to provide the flow required to operate the functions. Variable pumps are used to allow the delivery of a higher flow rate at lower working pressures, and then allow the pump to reduce flow at higher pressures to keep from stalling the engine. The increased flow at lower pressures makes the machine cycle faster, to increase the overall efficiency of the machine.

The engine horsepower required to drive a hydraulic pump depends on the flow delivered by the pump, as well as the pressure at which system is operating. There is a mathematical formula to calculate the pump drive horsepower, but a rule of thumb to visualize this, is that it requires approximately 1 engine horsepower to deliver 1 gallon per minute of oil at 1500 psi. Therefore, it would require 25 HP to deliver 25 GPM at 1500 psi. If the pressure increases to 3000 psi, the requirement would be 50 HP.

The CX Series Excavators have an automatic pump de-stroke feature that reduces pump flow to a minimum delivery when all control levers are in the neutral position. This is accomplished with a hydraulic pilot signal from the control valve. This system saves fuel and eliminates wasted engine and hydraulic power. The minimum flow delivery of the pumps increases with machine size and engine horsepower. Although the pump configuration and manufacturer varies, in principal, all of the pump control systems operate the same.

<b>Pumps</b>				
<b>MODEL</b>	<b>CX130</b>	<b>CX160</b>	<b>CX210</b>	<b>CX240</b>
<b>Max. pump flow X 2</b>	32.4 gpm	36.2 gpm	53.1gpm	56 gpm
<b>Pilot pump flow</b>	6 gpm	5.8 gpm	5.3 gpm	5.3 gpm
<b>Manufacture</b>	Uchida	Uchida	Kawasaki	Kawasaki
<b>Configuration</b>	Tandem	Tandem	Tandem	Tandem

# GENERAL INTRODUCTION

---

## EXPLANATION OF CX SERIES

### Pilot Controls

The attachment controls are pilot operated by hand actuated controllers on all models. The pilot hand controls are mounted to tilting armrests that can be positioned to provide for maximum operator comfort. The standard control pattern is the SAE pattern. The controls can be changed to other configurations by changing the pilot hose connections at the pilot manifold, located behind the cab (see Section 3 of this manual for instructions). There is a pattern change kit available as an option. This allows pattern changes without moving hoses.

When the left arm is tilted up or the gate is up, all pilot operated control functions are inactive.

On all models, the travel system is actuated by foot pedals that also have hand control levers attached. The travel controls are pilot pressure operated on all models. The CX240 has the single pedal feature, by actuating a single control pedal, both travel systems will travel at the same speed and direction. This feature gives the operator straight-line travel in either forward or reverse.

<b>Pilot Controls</b>				
<b>MODEL</b>	<b>CX130</b>	<b>CX160</b>	<b>CX210</b>	<b>CX240</b>
<b>Pilot operated hand and foot controls</b>	yes	yes	yes	yes
<b>Single pedal travel</b>	no	no	no	yes

# GENERAL INTRODUCTION

---

## EXPLANATION OF CX SERIES

### Hydraulic System Overview

All models use a triple hydraulic pump assembly that is located on the same side of the unit as the reservoir. All of the units use two variable displacement piston pumps for the machine functions. A fixed displacement gear pump used to supply pilot control oil for the system. The CX130 and CX160 units use a tandem mounted pump supplied by Uchida. The CX210 and CX240 units use a tandem mounted pump supplied by Kawasaki. All of the pumps have a system to limit the horsepower load on the engine. This system allows the unit to fully utilize the power available without overloading the engine. The CX Series Excavators have an electrically controlled feature that allows the hydraulic system to operate at less than full load to increase fuel economy or fine touch controllability.

This feature allows for four digging modes:

"Auto" -Variable- 90-85% engine speed- 93-90% hydraulic pump torque

"H" -Heavy Duty - 100% of engine speed - 100% hydraulic pump torque

"S" -Standard Duty - 95% of engine speed - 90% hydraulic pump torque

"L" -Light - 85% of engine speed - 70% hydraulic pump torque

The machine will be in the "**Auto**" mode each time it is started.

All models have Power Boost

CX130/CX160 machines have One-Touch Power Boost

CX210/CX240 machines have automatic Power Boost.

### EXPLANATION OF CX SERIES

#### **CX130/CX160/CX210/CX240 Hydraulic System**

There is a single main relief with a second (power boost) setting. Boom and arm anti-drift valves are built into the main control valve. An auxiliary control valve is standard and a factory installed or field installed kit with plumbing to the end of the arm is available. Other features that are built into the main control valve are:

- Dual flow boom up
- Boom down regeneration
- Boom down anti-drift
- Dual flow arm
- Arm in regeneration
- Arm in anti-drift
- Travel priority
- Swing priority
- Neutral pump de-stroke

Two electrical pressure switches are installed on the main control valve, and one in the swing pilot shuttle valve. These switches are used to tell the controller what hydraulic functions are being operated.

#### **Cushion Control System**

The CX Series units have an attachment control cushion system to allow the boom and arm cylinder control spools to gradually return to neutral, for shock-free operation. This feature allows a lesser skilled operator to work more smoothly. With the control cushion system active, the pilot oil from the hand control flows to the arm or boom control spool unrestricted. When the hand control is returned to neutral, the pilot oil is restricted as it leaves the control spool. This slow return of the spool accounts for the smooth operation. The system can be overridden with an electrical control switch on the monitor/switch panel.

#### **Swing**

The CX Series Excavators do not have a mechanical house lock. The house lock is accomplished with the swing brake. Swing lock or (100%) brake is applied when the switch on the left console is activated or the engine is shut off. The swing brake is applied 5 seconds after the control is returned to neutral.

# GENERAL INTRODUCTION

---

## EXPLANATION OF CX SERIES

### Travel CX130/CX160/CX200/CX220

The travel motors are located at the rear of each track assembly. The travel system is controlled by control spools in the main control valve located in the machine upper section. The travel drive system has independent, compact, axial piston, two speed hydraulic motors. Each track is independently driven by a sprocket driven by a planetary reduction unit. There is a spring applied hydraulically released disc brake built into each motor. The travel brake is released by the travel pressure applied to the motor. Each travel motor is equipped with a counterbalance valve and a dual stage relief valves for smooth starts and stops. The counterbalance valve prevents over speeding of the motor while driving down an incline. The shockless relief valve allows for additional cushioning in the circuit by allowing a slight transfer of oil between travel directions as the unit is started and stopped. The travel motors and reducers are mounted within the width of the side frame. Two-speed travel is controlled by the controller, which controls a solenoid valve. The travel speed solenoid supplies pilot circuit pressure to actuate the two-speed spool in each drive motor. Travel drive pressure is then ported through the two-speed control spool to the motor swash plates. The machines are in “**LOW SPEED**” travel when the key is turned on. When the travel switch is depressed the machine will be in “**HIGH SPEED**” and if the drive load is too high the motor will automatically shift to “**LOW SPEED**” and back to “**HIGH SPEED**” when the load is reduced.

The travel systems have a travel priority function to insure straight travel capability if the swing function or any attachment function is activated, while traveling. When traveling without other functions activated, one pump supplies right travel with the other pump supplying left travel. When the travel priority spool shifts, because of multiple function application, one pump is used to supply both right and left travel while the other pump is used for the attachment functions. With one pump supplying, both travel functions, the travel speed will naturally be reduced significantly.

Travel				
MODEL	CX130	CX160	CX210	CX240
L Speed	2.1			
H Speed	3.4			

## GENERAL INTRODUCTION

---

### EXPLANATION OF CX SERIES

#### **Cylinders**

The attachment cylinders have a cushion feature to hydraulically reduce the speed of the cylinder rod at the extreme ends of travel to limit the shock on the machine. Bucket open and boom down cylinder positions do not have cushions.

### EXPLANATION OF CX SERIES

#### Electrical System

All models have a 24-volt starting and charging system. The CX Series Excavators have two 12-volt batteries, wired in series to obtain the 24-volt capacity. These batteries are located in the compartment behind the cab.

There is a battery relay connected between the positive battery cable and the machine electrical system. The battery relay acts as the master disconnect for the system. The battery relay closes as the key switch is turned to the **"on"** position.

### EXPLANATION OF CX SERIES

#### Electrical System

To improve starting at cold temperatures the CX130 and CX160 are equipped with an ether injection system as standard equipment. The ether injection system can only be activated when the key-switch is in the crank position. There is a rocker switch located in the left-hand control console for easy access to the operator. There is also a temperature switch located on the engine intake manifold to prevent engagement of the ether system when the engine is above approximately 40°F . On the CX210 and CX240, an intake manifold heater is used for cold starting assist.

The Alternator is rated at 24 volts. The electronic controller for the CX130/CX160 machine requires an engine speed signal from a magnetic sensor on the flywheel. This engine speed signal is extremely critical to machine functions. The CX210/CX240 machines have electronic control engines. The machine controller requires input from the engine controller.

The engine, the hydraulic, and the electrical systems are all monitored by a controller. The controller for the CX130/CX160 is different than for the CX210/CX240. The controller receives signals from sending units. Very simply, the controller takes the information that it has received, and then sends the required outputs to cause the machine to perform as selected. These outputs may be sent to the display panel to indicate a malfunction or to give a visual display of which performance features have been selected. The outputs may also be sent to the solenoid valves, which control the machine functions. The controller has an automatic "limp home" feature to allow the machine to be operated to complete the job in case of controller failure.

# **CASE**

**Construction Equipment Service Training**

## **CX SERIES EXCAVATOR**



### **Section 2 -- Component Locations**

(2001)

**Training  
Pays**

**CASE CORPORATION**  
700 STATE STREET  
RACINE, WI 53404 U.S.A.

**CASE CANADA CORPORATION**  
3350 SOUTH SERVICE ROAD  
BURLINGTON, ON L7N 3M6 CANADA

© 2001 Case Corporation  
All Rights Reserved

Printed in U.S.A.

# COMPONENT LOCATIONS

---

## Table of Contents

### Section 2 - Component Locations

	<b>PAGE NO.</b>
MAIN COMPONENTS	
CX130/CX160 .....	2
CX210/CX240 .....	3
ELECTRICAL COMPONENTS	
CX130/CX160 .....	4-6
CX210/CX240 .....	7-9
All Models.....	10-12
CONTROL VALVE PORTS	
CX130/CX160 .....	13-15
PUMP PORTS	
CX130/CX160 .....	16
CONTROL VALVE PORTS	
CX210/CX240 .....	17-18
PUMP PORTS	
CX210/CX240 .....	19
SIX SOLENOID VALVE	
All Models.....	20

## COMPONENT LOCATIONS

---

### MAIN COMPONENTS

#### CX130/CX160

The CX130/CX160 could be considered sister machines because they are so similar. Electrically they are identical. Hydraulically the components are the same except for greater flow rates required by larger machines.

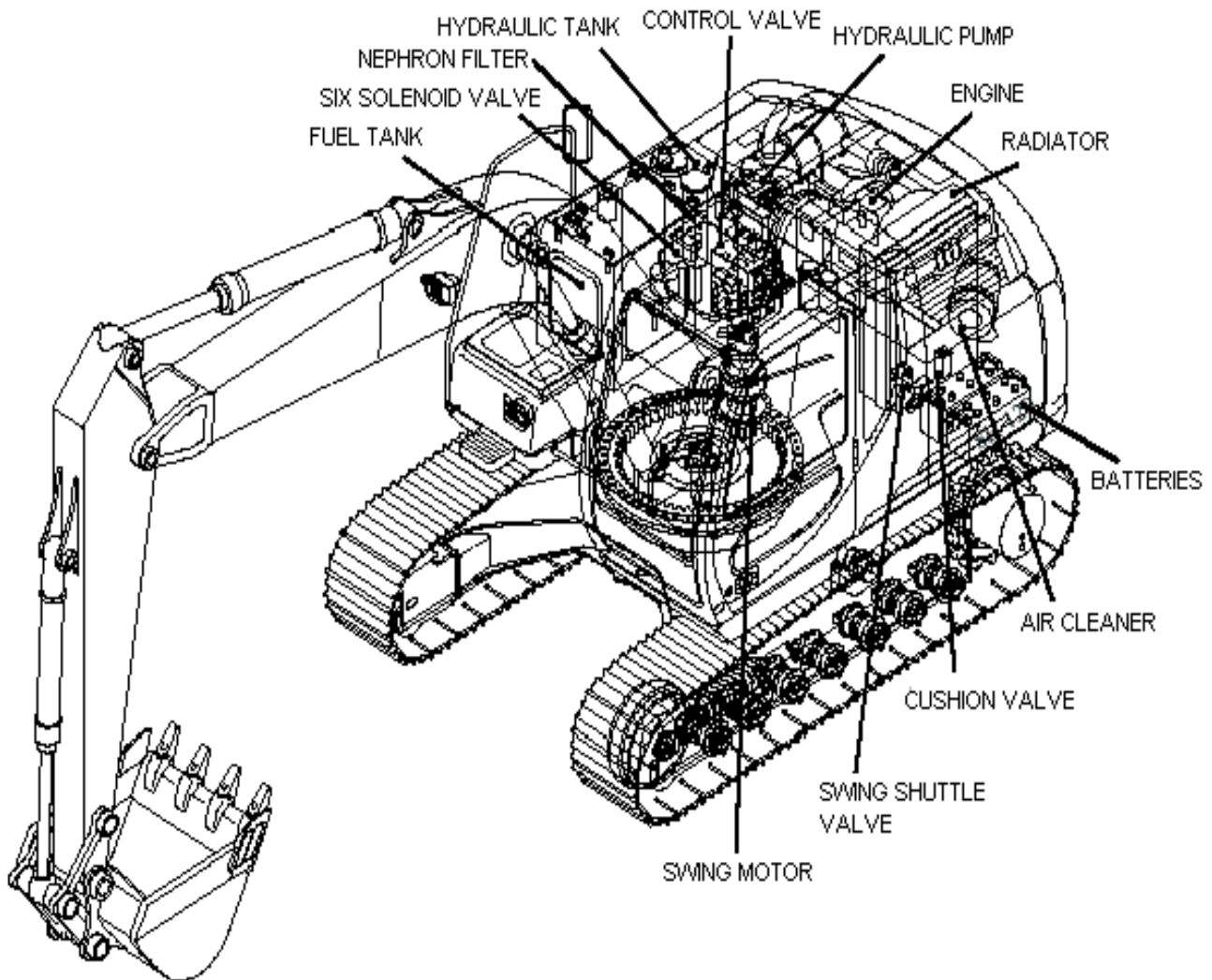

# COMPONENT LOCATIONS

## MAIN COMPONENTS

### CX210 / CX240

The CX210 / CX240 could be considered sister machines because they are so similar. Electrically they are identical. Hydraulically the components are the same except for greater flow rates required by larger machines.

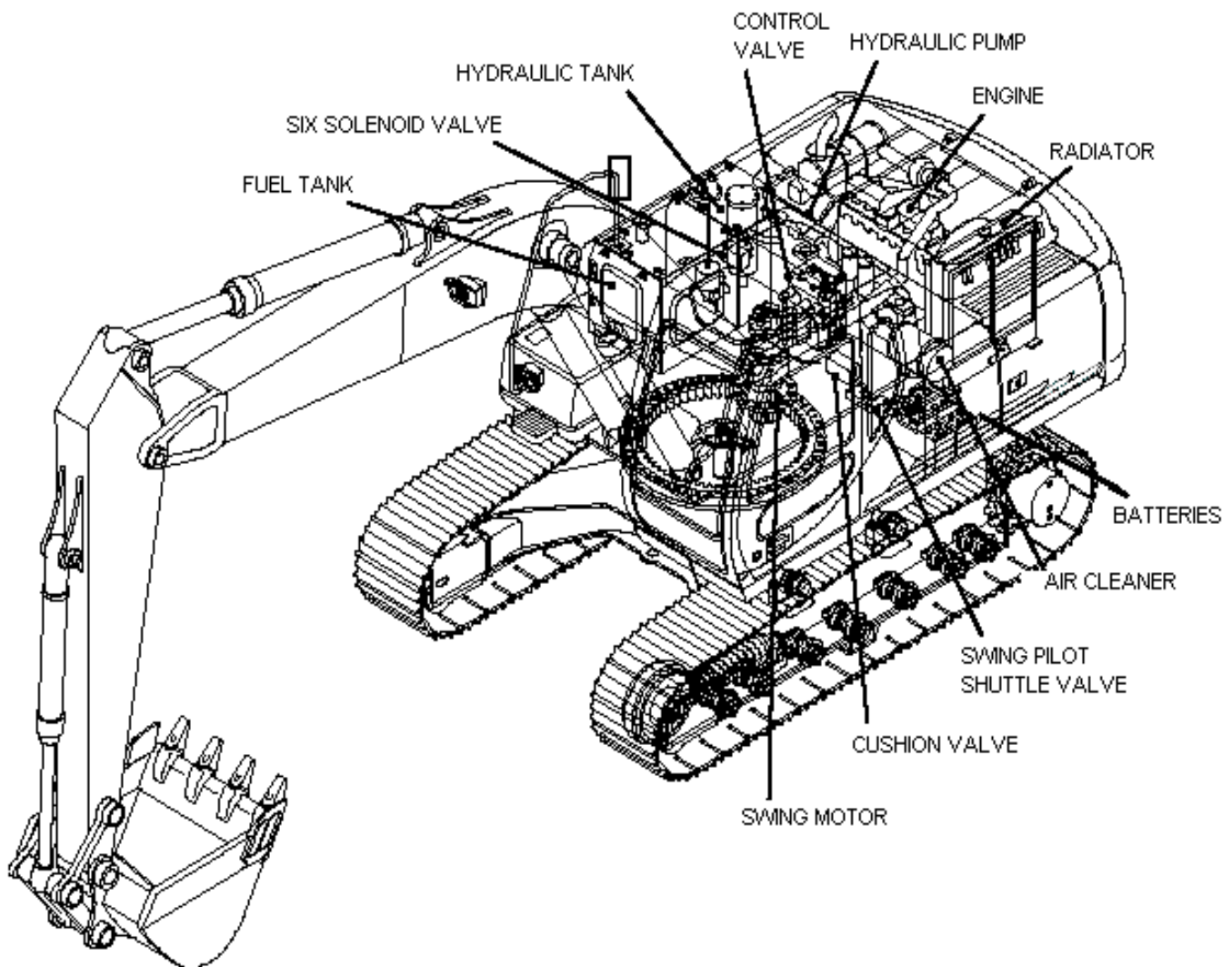

## COMPONENT LOCATIONS

---

### ELECTRICAL COMPONENTS

#### CX130 / CX160

Because of the similarity, the component locations are the same between CX130/CX160 .

#### Next Page: Out side of cab

- |  |  |
|--|--|
| 1. Free swing solenoid valve               | 14. Six solenoid valve bank                          |
| 2. Travel alarm                            | 15. Negative (de-stroke) pressure transducer (pump2) |
| 3. Boom light                              | 16. Pump2 pressure transducer                        |
| 4. Swing pilot pressure switch             | 17. Pump1 pressure transducer                        |
| 5. Horn (low note)                         | 18. Hydraulic oil temperature sender                 |
| 6. Horn (high note)                        | 19. Battery disconnect relay                         |
| 7. Upper pressure switch                   | 20. 20 amp fuse                                      |
| 8. Work light (upper-structure)            | 21. 20 amp fuse                                      |
| 9. Windshield washer motor                 | 22. 65 amp fuse                                      |
| 10. Not available on north american models | 23. Batteries  |
| 11. Fuel level sender                      | 24. Coolant level sender                             |
| 12. Travel pressure switch                 | 25. A/C compressor clutch switch                     |
| 13. Pump proportional solenoid valve       |  |

#### Page 6: Inside of cab

- |                                      |  |
|--------------------------------------|--|
| 1. Horn switch                       | 15. Radio                              |
| 2. Gate lever                        | 16. Cigarette lighter                  |
| 3. Auxiliary hydraulic select switch | 17. Air condition control              |
| 4. Door limit switch (A/C)           | 18. Key switch                         |
| 5. Air conditioner                   | 19. Throttle control                   |
| 6. Fuse box                          | 20. Instrument/switch panel            |
| 7. Machine electronic controller     | 21. One touch/auto idle control        |
| 8. Throttle motor driver             | 22. Windshield limit switch (A/C)      |
| 9. Engine emergency stop relay       | 23. Windshield wiper motor control box |
| 10. Work lights relay                | 24. Windshield wiper motor             |
| 11. Horn relay                       | 25. Cab interior light                 |
| 12. Ether start relay                | 26. Option switch                      |
| 13. DC-DC converter (24v-12v)        | 27. Power boost switch                 |
| 14. Solar radiation detector         | 28. Option relay                       |

# COMPONENT LOCATIONS

## ELECTRICAL COMPONENTS

### OUTSIDE OF THE CAB

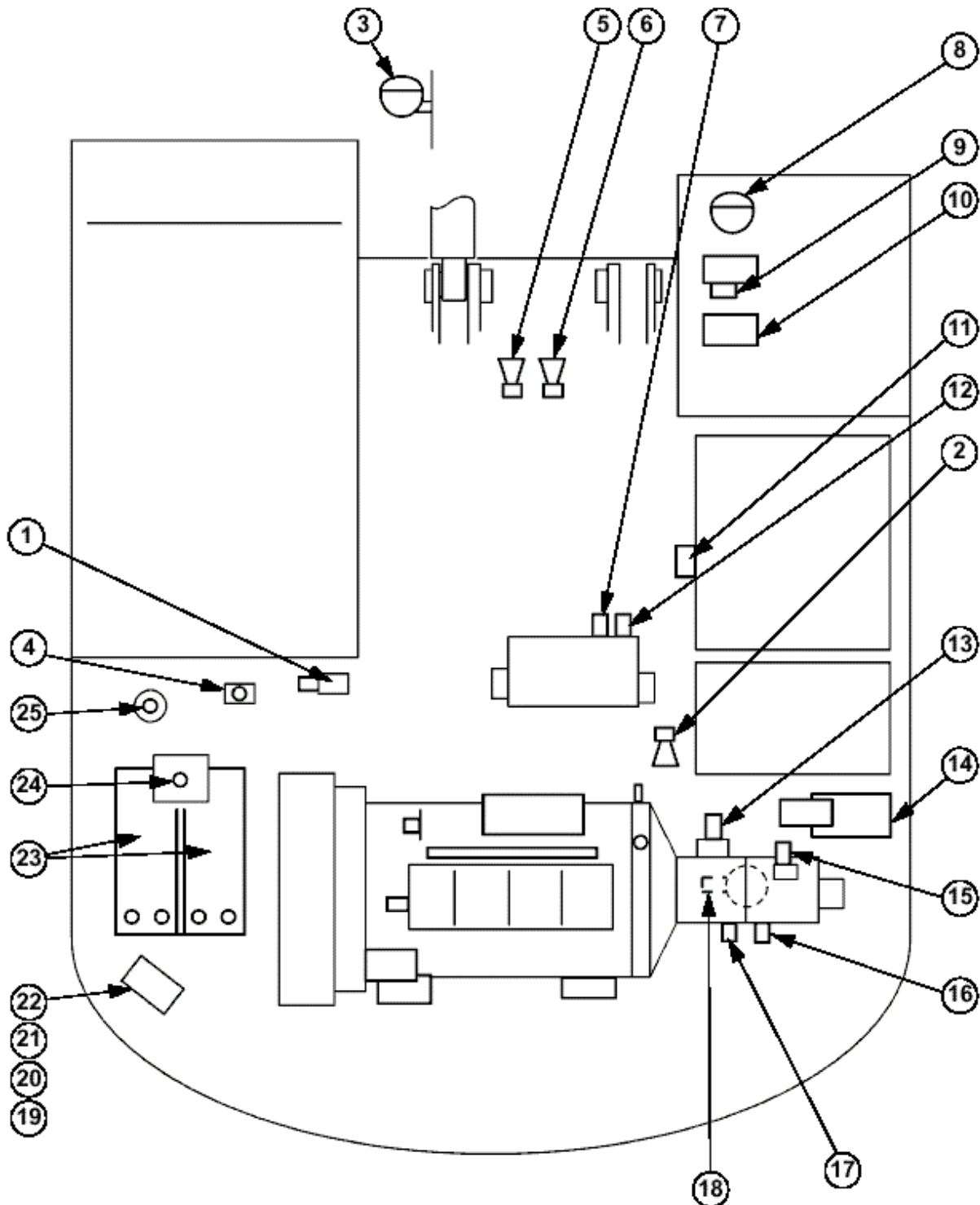

# COMPONENT LOCATIONS

## ELECTRICAL COMPONENTS

### INSIDE THE CAB

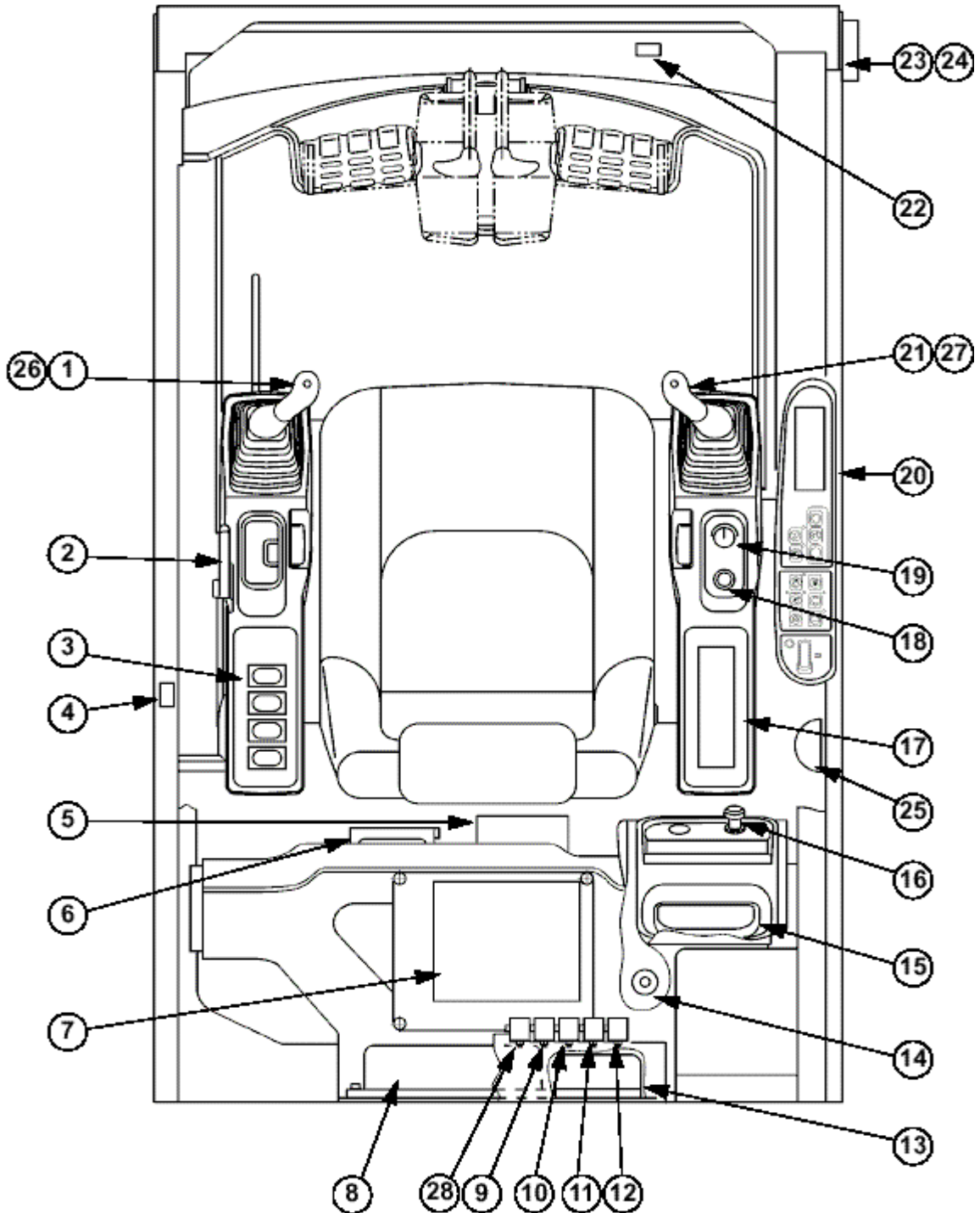

## COMPONENT LOCATIONS

---

### ELECTRICAL COMPONENTS

#### CX210 / CX240

Because of the similarity, the component locations are the same between CX210 / CX240.

#### Next Page: Outside the Cab

- |  |  |
|--|--|
| 1. Free swing solenoid valve               | 13. Pump proportional solenoid               |
| 2. Travel alarm                            | 14. Six solenoid valve                       |
| 3. Boom work light                         | 15. Negative (de-stroke) pressure transducer |
| 4. Swing pilot pressure switch             | 16. Pump2 pressure transducer                |
| 5. Horn (low note)                         | 17. Pump1 pressure transducer                |
| 6. Horn (high note)                        | 18. Hydraulic temperature sender             |
| 7. Upper pilot pressure switch             | 19. Battery disconnect relay                 |
| 8. Work light                              | 20. 20 amp fuse                              |
| 9. Windshield washer motor                 | 21. 20 amp fuse                              |
| 10. Not available on North American models | 22. 65 amp fuse                              |
| 11. Fuel level sender                      | 23. Batteries                                |
| 12. Travel pilot pressure switch           | 24. A/C compressor clutch switch             |

#### Page 9: Inside the Cab

- |                                |                                       |
|--------------------------------|---------------------------------------|
| 1. Horn switch                 | 14. Solar radiation sensor            |
| 2. Gate lock lever             | 15. Radio                             |
| 3. Auxiliary select switch     | 16. Cigarette lighter                 |
| 4. Door limit switch (A/C)     | 17. Air condition control             |
| 5. Air conditioner             | 18. Key switch                        |
| 6. Fuse box                    | 19. Throttle control                  |
| 7. Machine controller          | 20. Instrument/switch panel           |
| 8. Option switch (left)        | 21. Engine control                    |
| 9. Engine emergency stop relay | 22. Windshield limit switch (A/C)     |
| 10. Work lights relay          | 23. Windshield wiper motor controller |
| 11. Horn relay                 | 24. Windshield wiper motor            |
| 12. Option switch (right)      | 25. Cab interior light                |
| 13. DC-DC converter (24v-12v)  |                                       |

THANK YOU FOR VISITE WITH

[www.repair-manuals.com](http://www.repair-manuals.com)

**DOWNLOAD THIS FULL MANUAL**

**Until download and place it on your computer We care with you ,We really try our best to complete your orders, so your review is very important to us to improve our services**

WE OFFER

ORIGINAL FACTORY MANUALS , WORKSHOP  
MANUALS , SERVICE MANUALS , REPAIR

OUR VISION : 100 % CUSTOMER SATISFACTION,  
AFTER SALE SERVICE AND KEEP IN TOUCH WITH