

**850J-II
Crawler Dozer
Repair**

(PIN: 1T0850JJ__D306725—)

REPAIR TECHNICAL MANUAL

**850J-II Crawler Dozer
(PIN: 1T0850JJ__D306725—)**

TM14231X19 18APR19 (ENGLISH)

Introduction

Foreword

This manual is written for an experienced technician. Essential tools required in performing certain service work are identified in this manual and are recommended for use.

Live with safety: Read the safety messages in the introduction of this manual and the cautions presented throughout the text of the manual.

 This is the safety-alert symbol. When you see this symbol on the machine or in this manual, be alert to the potential for personal injury.

Technical manuals are divided in two parts: repair and operation and tests. Repair sections tell how to repair the components. Operation and tests sections help you identify the majority of routine problems quickly.

Information is organized in groups for the various components requiring service instruction. At the beginning of each group are summary listings of all applicable essential tools, service equipment and tools, other materials needed to do the job, service parts kits, specifications, wear tolerances, and torque values.

Technical Manuals are concise guides for specific machines. They are on-the-job guides containing only the vital information needed for diagnosis, analysis, testing, and repair.

Fundamental service information is available from other sources covering basic theory of operation, fundamentals of troubleshooting, general maintenance, and basic type of problems and their causes.

TX,750C,SS2406 -19-13JUL95-1/1

Introduction

Contents

Section 00—General Information

- Group 01—Safety
- Group 03—Torque Values

Section 01—Tracks

- Group 0130—Track System

Section 02—Axles and Suspension Systems

- Group 0201—Drive Axle Housing and Support
- Group 0250—Axle Shaft, Bearings and Reduction Gears

Section 03—Transmission

- Group 0300—Remove and Install
- Group 0315—Control Linkage
- Group 0360—Hydrostatic System

Section 04—Engine

- Group 0400—Removal and Installation

Section 05—Engine Auxiliary Systems

- Group 0505—Cold Weather Starting Aid
- Group 0510—Cooling System
- Group 0515—Engine Speed Control
- Group 0530—External Exhaust Systems
- Group 0560—External Fuel Supply Systems

Section 07—Damper Drive

- Group 0752—Elements

Section 11—Park Brake

- Group 1100—Park Brake
- Group 1115—Control Linkage
- Group 1160—Hydraulic System

Section 15—Equipment Attaching

- Group 1511—Drawbar

Section 17—Frames, Chassis, or Supporting Structure

- Group 1740—Frame Installation
- Group 1746—Frame Bottom Guards
- Group 1749—Chassis Weights

Section 18—Operator's Station

- Group 1800—Removal and Installation
- Group 1810—Operator Enclosure
- Group 1821—Seat and Seat Belt

- Group 1830—Heating and Air Conditioning

Section 19—Sheet Metal

- Group 1910—Hood and Engine Enclosures

Section 20—Safety, Convenience and Miscellaneous

- Group 2004—Horn and Warning Devices

Section 32—Bulldozer

- Group 3201—Blade
- Group 3240—Frames
- Group 3260—Hydraulic System

Section 42—Ground Conditioning Tool

- Group —Ripper

Section 9900—Dealer Fabricated Tools

- Group 0999—Dealer Fabricated Tools

Original Instructions. All information, illustrations and specifications in this manual are based on the latest information available at the time of publication. The right is reserved to make changes at any time without notice.

COPYRIGHT © 2019
DEERE & COMPANY
Moline, Illinois
All rights reserved.
A John Deere ILLUSTRATION™ Manual
Previous Editions
Copyright © 2017, 2018

Contents

Section 00 General Information

Contents

	Page		Page
Group 01—Safety			
Information for European Union		Remove Paint Before Welding or Heating	00-01-17
Directives and Eurasian Economic Union Technical Regulations Compliance.....	00-01-1	Make Welding Repairs Safely	00-01-17
Recognize Safety Information	00-01-2	Drive Metal Pins Safely	00-01-17
Follow Safety Instructions.....	00-01-3	Use Proper Lifting Equipment.....	00-01-18
Operate Only If Qualified	00-01-3		
Wear Protective Equipment.....	00-01-3	Group 03—Torque Values	
Avoid Unauthorized Machine Modifications.....	00-01-4	Torque Value	
Inspect Machine	00-01-4	Metric Bolt and Cap Screw.....	00-03-1
Stay Clear of Moving Parts.....	00-01-4	Additional Metric Cap Screw Torque Values.....	00-03-2
Avoid High-Pressure Fluids	00-01-5	Unified Inch Bolt and Cap Screw	00-03-3
Avoid High-Pressure Oils	00-01-5	Service Recommendations for 37° Flare and 30° Cone Seat Connectors	00-03-4
Work In Ventilated Area.....	00-01-5	Service Recommendations for O-Ring Boss Fittings.....	00-03-4
Avoid Static Electricity Risk When Refueling	00-01-6	Service Recommendation O-Ring Boss Fittings In Aluminum HousingExcavators.....	00-03-6
High Debris Applications	00-01-6	Service Recommendations for Flared Connections—Straight or Tapered Threads	00-03-7
Prevent Fires	00-01-7	Service Recommendations For Flat Face O-Ring Seal Fittings	00-03-8
In Case of Machine Fire	00-01-7	O-Ring Face Seal Fittings with SAE Inch Hex Nut and Stud End for High Pressure.....	00-03-9
Prevent Battery Explosions	00-01-8	O-Ring Face Seal Fittings with Metric Hex Nut and Stud End for Standard Pressure.....	00-03-11
Handle Chemical Products Safely.....	00-01-8	O-Ring Face Seal Fittings with Metric Hex Nut and Stud End for High Pressure.....	00-03-13
Handle Starting Fluid Safely.....	00-01-8	Service Recommendations for Metric Series Four Bolt Flange Fitting.....	00-03-15
Decommissioning — Proper Recycling and Disposal of Fluids and Components	00-01-9	Service Recommendations For Inch Series Four Bolt Flange Fittings.....	00-03-16
Prepare for Emergencies.....	00-01-9	Inch Series Four Bolt Flange Fitting For High Pressure Service Recommendations.....	00-03-17
Clean Debris from Machine	00-01-10	Service Recommendations For Non-Restricted Banjo (Adjustable) Fittings.....	00-03-18
Add Cab Guarding for Special Uses	00-01-10	Service Recommendations For O-Ring Boss Fittings With Shoulder	00-03-19
Use Steps and Handholds Correctly	00-01-10	Metric 24 O-Ring Seal DIN 20078.....	00-03-21
Start Only From Operator's Seat	00-01-10		
Use and Maintain Seat Belt.....	00-01-11		
Prevent Unintended Machine Movement.....	00-01-11		
Avoid Work Site Hazards.....	00-01-12		
Keep Riders Off Machine	00-01-12		
Avoid Backover Accidents.....	00-01-13		
Avoid Machine Tip Over and Machine Damage	00-01-13		
Use Special Care When Operating.....	00-01-13		
Inspect and Maintain ROPS	00-01-14		
Travel Safely.....	00-01-14		
Prevent Acid Burns.....	00-01-15		
Add and Operate Attachments Safely.....	00-01-15		
Park and Prepare for Service Safely.....	00-01-16		
Service Machines Safely	00-01-16		
Service Cooling System Safely	00-01-16		

Contents

Information for European Union Directives and Eurasian Economic Union Technical Regulations Compliance

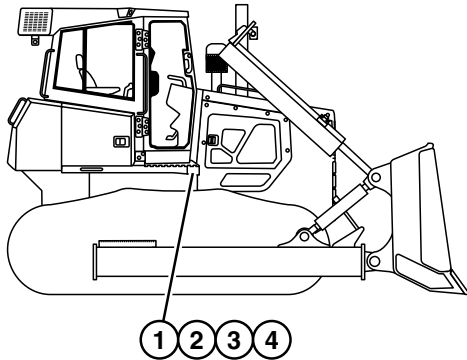

Crawler Dozer

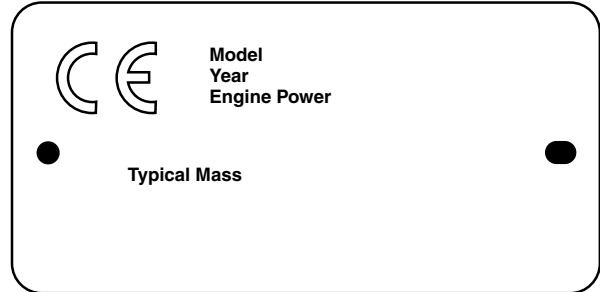

CE Mark



PIN Plate

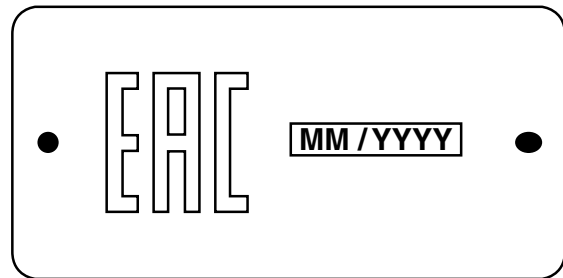

EAC Marking

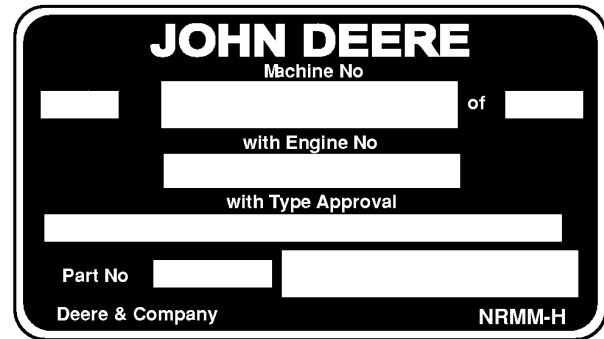

EU Flex Label

To the Customer

Effective June, 2006, all machines sold in the European Union must comply with the machinery directive 2006/42/EC and any amendments. Each machine meeting these requirements must bear the conformity mark CE. In addition, each machine must be accompanied with a Declaration of Conformity by the machine manufacturer. This declaration must be kept with the machine at all times and does not declare conformity to national road regulations.

Effective February 15, 2013, all machines sold in the Eurasian Economic Union must comply with the Technical Regulations of the Eurasian Economic Union TR TS 010/2011 "On Safety of machinery and Equipment." Each machine meeting these requirements must bear the EAC Marking.

NOTE: This machine may need country approval for travel on public roads in Europe as some European countries require special equipment and approvals.

Product Identification Number (PIN), CE Mark, EAC Marking, and EU Flex Label Locations

- 1— PIN Plate
- 2— CE Mark (if required)
- 3— EAC Marking (if required)
- 4— EU Flex Label (if required)

The machine is identified by the PIN that is stamped on a serial number plate. The PIN plate (1), CE Mark or EAC Marking, and if required, EU flex label are located on the machine as indicated in the machine image.

Safety

NOTE: If this machine was certified (homologated) to the requirements of the European Union, there will be a CE mark affixed in indicated area (2). If required this machine will also be affixed with an EU Flex label (4) beside the CE mark in the indicated area.

If this machine was certified (homologated) to the requirements of the Eurasian Economic Union, there will be a EAC marking (3) affixed in the indicated area.

Sound and Vibration Specifications

Model	850J-II
Operator sound pressure and exterior sound power levels are:	
Cab	81 dB(A) and 109 dB(A) or less *
<p><i>NOTE: Factors affecting listed values include operator performance, machine age, seat condition, the use of accessories, environment, and any machine movement.</i></p> <p><i>(*) Data acquisition system precision values with a 2% technical uncertainty.</i></p> <p>Sound levels were obtained using the test method specified per ISO 6396:2008 and ISO 6395:2008, respectively.</p>	
<p>Eurasian Economic Union Operator vibration levels are for properly maintained machines operating on a flat dirt area free of large objects such as trees and rocks. Whole body vibration levels were obtained using the test method specified per GOST 31191.1:2004.</p>	
Whole Body	0.5 m/s ² or less
Hand Arm	2.5 m/s ² or less
<p><i>NOTE: Factors affecting listed values include operator performance, machine age, the condition of window and door seals, the use of accessories, environment, and any machine movement.</i></p>	
<p>European Union Operator vibration levels are for properly maintained machines operating on a flat dirt area free of large objects such as trees and rocks. Vibration levels were obtained using the test method specified per ISO 2631-1:1997 or ISO TR 25398 where applicable.</p>	
Whole Body	0.81 m/s ² or less
Hand Arm	2.5 m/s ² or less
<p><i>NOTE: Factors affecting listed values include operator performance, machine age, the condition of window and door seals, the use of accessories, environment, and any machine movement.</i></p>	

MB60223,000501C -19-05JAN17-2/2

Recognize Safety Information

This is the safety alert symbol. When you see this symbol on your machine or in this manual, be alert for the potential of personal injury.

Follow the precautions and safe operating practices highlighted by this symbol.

A signal word — DANGER, WARNING, or CAUTION — is used with the safety alert symbol. DANGER identifies the most serious hazards.

On your machine, DANGER signs are red in color, WARNING signs are orange, and CAUTION signs are yellow. DANGER and WARNING signs are located near specific hazards. General precautions are on CAUTION labels.



T133555 —UN—15APR13

T133558 —19—28AUG00

TX,RECOGNIZE -19-28JUN10-1/1

Follow Safety Instructions

Carefully read all safety messages in this manual and on your machine safety signs. Keep safety signs in good condition. Replace missing or damaged safety signs. Use this operator's manual for correct safety sign placement. Be sure that new equipment components and repair parts include the current safety signs. Replacement safety signs are available from your John Deere dealer.

There can be additional safety information contained on parts and components sourced from suppliers that is not reproduced in this operator's manual.

Learn how to operate the machine and how to use controls properly. Do not let anyone operate without instruction.

Keep your machine in proper working condition. Unauthorized modifications to the machine could impair the function or safety and affect machine life.

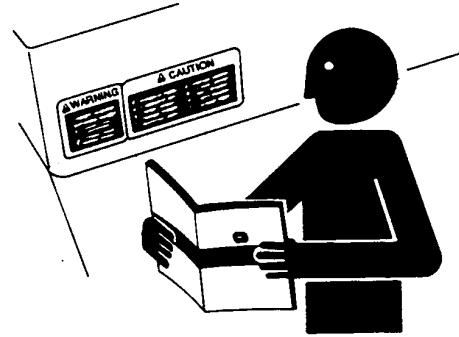

If you do not understand any part of this manual and need assistance, contact your John Deere dealer.

TX,FOLLOW -19-20JAN11-1/1

TS201—UN—15APR13

Operate Only If Qualified

Do not operate this machine unless the operator's manual has been read carefully, and you have been qualified by supervised training and instruction.

Operator should be familiar with the job site and surroundings before operating. Try all controls and

machine functions with the machine in an open area before starting to work.

Know and observe all safety rules that may apply to every work situation and work site.

TX,QUALIFIED -19-18JAN11-1/1

Wear Protective Equipment

Guard against injury from flying pieces or metal or debris; wear goggles or safety glasses.

Wear close fitting clothing and safety equipment appropriate to the job.

Operating equipment safely requires the full attention of the operator. Do not wear radio or music headphones while operating machine.

Prolonged exposure to loud noise can cause impairment or loss of hearing. Wear suitable hearing protection such as earmuffs or earplugs to protect against objectionable or uncomfortable loud noises. Radio or music headphones are not suitable to use for hearing protection.

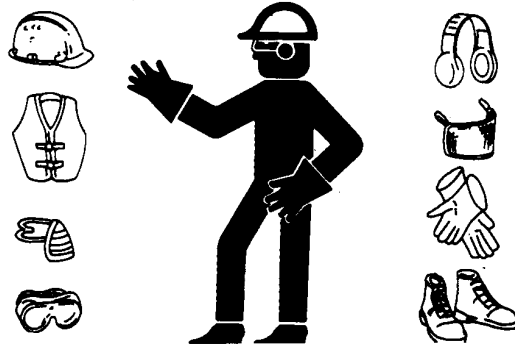

TX,WEAR,PE -19-22SEP10-1/1

TS206—UN—15APR13

Avoid Unauthorized Machine Modifications

John Deere recommends using only genuine John Deere replacement parts to ensure machine performance. Never substitute genuine John Deere parts with alternate parts not intended for the application as these can create hazardous situations or hazardous performance. Non-John Deere parts, or any damage or malfunctions resulting from their use, are not covered by any John Deere warranty.

Modifications to this machine or addition of unapproved products or attachments may affect machine stability or

reliability and may create a hazard for the operator or others near the machine. The installer of any modification that may affect the electronic controls of this machine is responsible for establishing that the modification does not adversely affect the machine or its performance.

Always contact an authorized dealer before making machine modifications that change the intended use, weight, or balance of the machine or that alter machine controls, performance, or reliability.

KR46761,00010A9 -19-19FEB19-1/1

Inspect Machine

Inspect machine carefully each day by walking around it before starting.

Keep all guards and shields in good condition and properly installed. Fix damage and replace worn or broken parts immediately. Pay special attention to hydraulic hoses and electrical wiring.



T6607AQ—UN—15APR13

TX,INSPECT -19-08SEP10-1/1

Stay Clear of Moving Parts

Entanglements in moving parts can cause serious injury.

Stop engine before examining, adjusting, or maintaining any part of machine with moving parts.

Keep guards and shields in place. Replace any guard or shield that has been removed for access as soon as service or repair is complete.

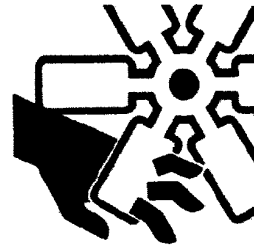

T133592—UN—15APR13

TX,MOVING,PARTS -19-20JAN11-1/1

Avoid High-Pressure Fluids

Escaping fluid under pressure can penetrate the skin causing serious injury.

Avoid the hazard by relieving pressure before disconnecting hydraulic or other lines. Tighten all connections before applying pressure.

Search for leaks with a piece of cardboard. Protect hands and body from high-pressure fluids.

If an accident occurs, see a doctor immediately. Any fluid injected into the skin must be surgically removed within a few hours or gangrene may result. Doctors unfamiliar with this type of injury should reference a knowledgeable medical source. Such information is available from Deere & Company Medical Department in Moline, Illinois, U.S.A.

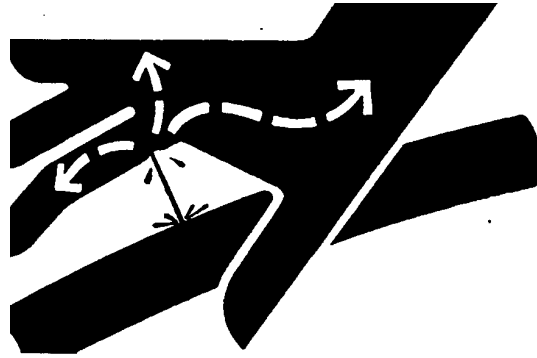

X9811 —UN—23AUG88

DX,FLUID -19-06OCT16-1/1

Avoid High-Pressure Oils

This machine uses a high-pressure hydraulic system. Escaping oil under pressure can penetrate the skin causing serious injury.

Never search for leaks with your hands. Protect hands. Use a piece of cardboard to find location of escaping oil. Stop engine and relieve pressure before disconnecting lines or working on hydraulic system.

If hydraulic oil penetrates your skin, see a doctor immediately. Injected oil must be removed surgically within hours or gangrene could result. Contact a knowledgeable medical source or the Deere & Company Medical Department in Moline, Illinois, U.S.A.

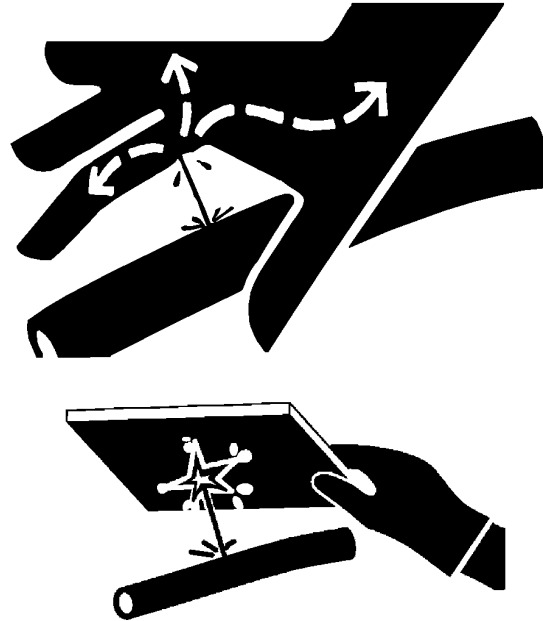

T133509 —UN—15APR13

T133840 —UN—20SEPO0

TX,HPOILS -19-20JAN11-1/1

Work In Ventilated Area

Engine exhaust fumes can cause sickness or death. If it is necessary to run an engine in an enclosed area, remove the exhaust fumes from the area with an exhaust pipe extension.

If you do not have an exhaust pipe extension, open the doors and get outside air into the area.

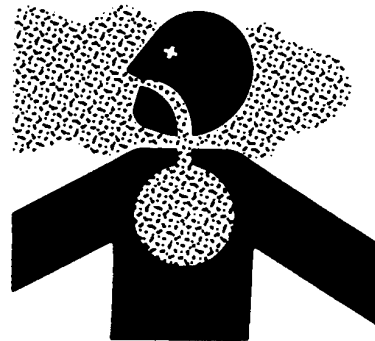

TS220 —UN—15APR13

DX,AIR -19-17FEB99-1/1

Avoid Static Electricity Risk When Refueling

The removal of sulfur and other compounds in Ultra-Low Sulfur Diesel (ULSD) fuel decreases its conductivity and increases its ability to store a static charge.

Refineries may have treated the fuel with a static dissipating additive. However, there are many factors that can reduce the effectiveness of the additive over time.

Static charges can build up in ULSD fuel while it is flowing through fuel delivery systems. Static electricity discharge when combustible vapors are present could result in a fire or explosion.

Therefore, it is important to ensure that the entire system used to refuel your machine (fuel supply tank, transfer pump, transfer hose, nozzle, and others) is properly grounded and bonded. Consult with your fuel or fuel system supplier to ensure that the delivery system is in compliance with fueling standards for proper grounding and bonding practices.

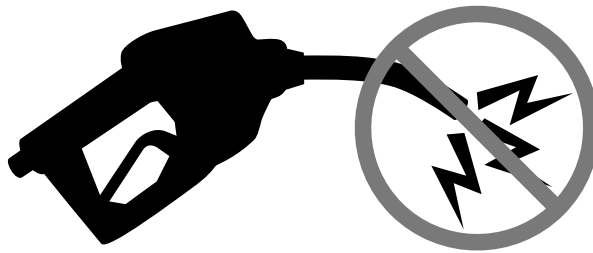

RG22142 —UN—17MAR14

RG21992 —UN—21AUG13

DX,FUEL,STATIC,ELEC -19-12JUL13-1/1

High Debris Applications

Many operations create flammable debris such as mulching, shredding, recycling, and agricultural applications. Operating in such environments may require frequent cleaning of the machine and attachments. Frequency of cleaning will vary depending on a number of factors, including operating conditions and weather.



Flammable Debris

T133552 —UN—15APR13

MB60223,0005003 -19-29JUN16-1/1

Prevent Fires

Handle Fluids Safely: All fuels, most lubricants, and some coolant mixtures are flammable. Store flammable fluids away from fire hazards. Never refuel machine while smoking or when near sparks or flame.

Clean Machine Regularly: Keep flammable debris (trash, leaves, twigs, straw, and so forth), grease and oil from accumulating in engine compartment, around fuel lines, hydraulic lines, exhaust components, and electrical wiring. Never store oily rags or flammable materials inside a machine compartment.

Maintain Hoses, Tubes, and Wiring: Replace hoses and tubes immediately if they begin to leak, and clean up any oil spills. Examine electrical wiring and connectors frequently for damage.

Keep A Fire Extinguisher Available: Always keep a multipurpose fire extinguisher on or near the machine. Know how to use an extinguisher properly.

Be Aware of the Operating Environment: Airborne debris may contain sparks or embers. Do not operate near any flame.



T133553 —UN—07SEP00



T133554 —UN—07SEP00



TX,PREVENT,FIRE -19-09JUN16-1/1

In Case of Machine Fire

CAUTION: Avoid personal injury from exposed flames. Maintain safe distance.

- Turn the engine off.
- Turn the battery disconnect switch to the OFF position (if equipped).
- If possible, fight the fire using the portable fire extinguisher or other fire suppression equipment (if equipped).
- Ensure that the fire does not spread to the surrounding area. Do not risk injury. If a fire is too far advanced, do not try to extinguish fire.
- Call for help.



In Case of Machine Fire

CN93077.00000B2 -19-05FEB19-1/1

Prevent Battery Explosions

Keep sparks, lighted matches, and open flame away from the top of battery. Battery gas can explode.

Never check battery charge by placing a metal object across the posts. Use a voltmeter or hydrometer.

Do not charge a frozen battery; it may explode. Warm battery to 16°C (60°F).

Keep battery electrolyte levels properly maintained.



Battery Explosions

TS204—JUN—15APR13

KR46761,00010B4 -19-26JAN16-1/1

Handle Chemical Products Safely

Direct exposure to hazardous chemicals can cause serious injury. Potentially hazardous chemicals used with John Deere equipment include such items as lubricants, coolants, paints, and adhesives.

A Material Safety Data Sheet (MSDS) provides specific details on chemical products: physical and health hazards, safety procedures, and emergency response techniques.

Check the MSDS before you start any job using a hazardous chemical. That way you will know exactly what the risks are and how to do the job safely. Then follow procedures and recommended equipment.

(See your John Deere dealer for MSDS's on chemical products used with John Deere equipment.)

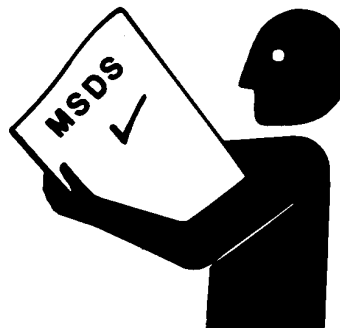

TS1132—JUN—15APR13

DX,MSDS,NA -19-03MAR93-1/1

Handle Starting Fluid Safely

Starting fluid is highly flammable.

Keep all sparks and flame away when using it. Keep starting fluid away from batteries and cables.

To prevent accidental discharge when storing the pressurized can, keep the cap on the container, and store in a cool, protected location.

Do not incinerate or puncture a starting fluid container.

Do not use starting fluid on an engine equipped with glow plugs or an air intake heater.



TS1356—JUN—18MAR92

DX,FIRE3 -19-14MAR14-1/1

Decommissioning — Proper Recycling and Disposal of Fluids and Components

Safety and environmental stewardship measures must be taken into account when decommissioning a machine and/or component. These measures include the following:

- Use appropriate tools and personal protective equipment such as clothing, gloves, face shields or glasses, during the removal or handling of objects and materials.
- Follow instructions for specialized components.
- Release stored energy by lowering suspended machine elements, relaxing springs, disconnecting the battery or other electrical power, and releasing pressure in hydraulic components, accumulators, and other similar systems.
- Minimize exposure to components which may have residue from agricultural chemicals, such as fertilizers and pesticides. Handle and dispose of these components appropriately.
- Carefully drain engines, fuel tanks, radiators, hydraulic cylinders, reservoirs, and lines before recycling components. Use leak-proof containers when draining fluids. Do not use food or beverage containers.
- Do not pour waste fluids onto the ground, down a drain, or into any water source.
- Observe all national, state, and local laws, regulations, or ordinances governing the handling or disposal of waste fluids (example: oil, fuel, coolant, brake fluid);

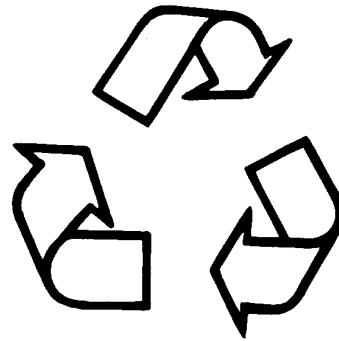

- filters; batteries; and, other substances or parts. Burning of flammable fluids or components in other than specially designed incinerators may be prohibited by law and could result in exposure to harmful fumes or ashes.
- Service and dispose of air conditioning systems appropriately. Government regulations may require a certified service center to recover and recycle air conditioning refrigerants which could damage the atmosphere if allowed to escape.
- Evaluate recycling options for tires, metal, plastic, glass, rubber, and electronic components which may be recyclable, in part or completely.
- Contact your local environmental or recycling center, or your John Deere dealer for information on the proper way to recycle or dispose of waste.

DX,DRAIN -19-01JUN15-1/1

TS1133 —UN—15APR13

Prepare for Emergencies

Be prepared if a fire starts.

Keep a first aid kit and fire extinguisher handy.

Keep emergency numbers for doctors, ambulance service, hospital, and fire department near your telephone.

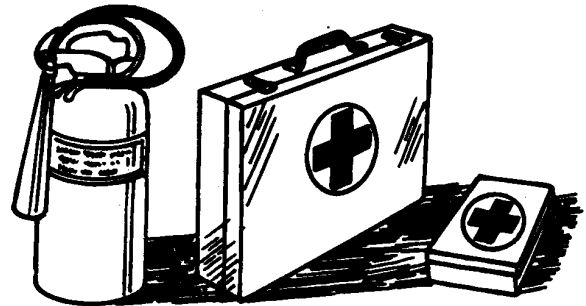

DX,FIRE2 -19-03MAR93-1/1

TS291 —UN—15APR13

Clean Debris from Machine

Keep engine compartment, radiator, batteries, hydraulic lines, exhaust components, fuel tank, and operator's station clean and free of debris.

Clean any oil spills or fuel spills on machine surfaces.

Temperature in engine compartment could go up immediately after engine is stopped. **BE ON GUARD FOR FIRES DURING THIS PERIOD.**

Open access door(s) to cool the engine faster, and clean engine compartment.

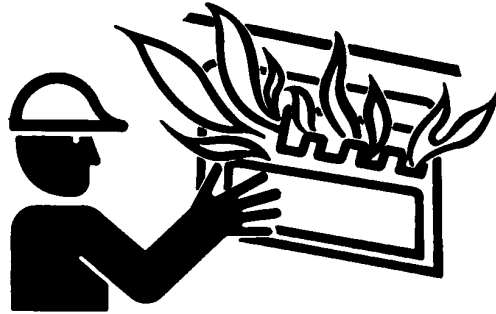

T6669AG—UN—15APR13

TX,DEBRIS -19-20JAN11-1/1

Add Cab Guarding for Special Uses

Special work situations or machine attachments could create an environment with falling or flying objects. Working near an overhead bank, demolition work, using a hydraulic hammer or winch, working in a forestry application or wooded area, or working in a waste management application, for example, could require added guarding to protect the operator.

Additional level II FOPS (falling object protective structure), forestry protection packages, and special screens or guarding should be installed when falling or flying objects could enter or damage the machine. A rear screen should always be used with a winch to protect against a snapping cable. Before operating in any special work environments, follow the operator protection recommendations of the manufacturer of any specialized attachment or equipment. Contact your authorized John Deere dealer for information on protective guarding.

TX,CABGUARD -19-12FEB13-1/1

Use Steps and Handholds Correctly

Prevent falls by facing the machine when you get on and off. Maintain 3-point contact with steps and handrails. Never use machine controls as handholds.

Use extra care when mud, snow, or moisture present slippery conditions. Keep steps clean and free of grease or oil. Never jump when exiting machine. Never mount or dismount a moving machine.

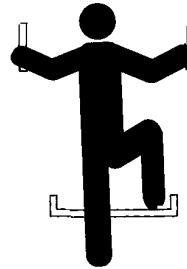

T133468—UN—15APR13

TX,STEPS -19-09FEB11-1/1

Start Only From Operator's Seat

Avoid unexpected machine movement. Start engine only while sitting in operator's seat. Ensure that all controls and working tools are in proper position for a parked machine.

Never attempt to start engine from the ground. Do not attempt to start engine by shorting across the starter solenoid terminals.



T133715—UN—15APR13

TX,SOFOS -19-20JAN11-1/1

Use and Maintain Seat Belt

Use seat belt when operating machine. Remember to fasten seat belt when loading and unloading from trucks and during other uses.

Examine seat belt frequently. Be sure that webbing is not cut or torn. Replace seat belt immediately if any part is damaged or does not function properly.

The complete seat belt assembly should be replaced every 3 years, regardless of appearance.



USE SEAT BELT

Use and Maintain Seat Belt

CN93077,0000340 -19-05FEB19-1/1

TX1165594 —19—23JUL14

Prevent Unintended Machine Movement

Always move the park lock lever to the up (locked) position before leaving the operator's seat for any reason.

Be careful not to accidentally actuate controls when coworkers are present. Engage park lock and lower work equipment to the ground during work interruptions. Stop the engine before allowing anyone to approach the machine. Follow these same precautions before standing up, leaving the operator's seat, or exiting the machine.

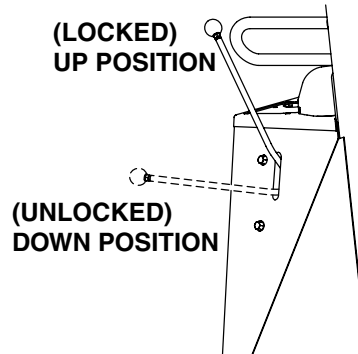

TX03768,0000B72 -19-23NOV10-1/1

T207688 —19—31JAN05

Avoid Work Site Hazards

Avoid contact with gas lines, buried cables and water lines. Call utility line location services to identify all underground utilities before starting work.

Prepare work site properly. Avoid operating near structures or objects that could fall onto the machine. Clear away debris that could move unexpectedly if run over.

Avoid boom or attachment contact with overhead obstacles or overhead electrical lines. Never move machine closer than 3 m (10 ft) plus twice the line insulator length to overhead wires.

Keep bystanders clear at all times. Keep bystanders away from raised booms, attachments, and unsupported loads. Avoid swinging or raising booms, attachments, or loads over or near personnel. Use barricades or a signal person to keep vehicles and pedestrians away. Use a signal person if moving machine in congested areas or where visibility is restricted. Always keep signal person in view. Coordinate hand signals before starting machine.

Operate only on solid footing with strength sufficient to support machine. Be especially alert working near embankments or excavations.

Avoid working under over-hanging embankments or stockpiles that could collapse under or on machine.

Reduce machine speed when operating with tool on or near ground when obstacles may be hidden (e.g., during snow removal or clearing mud, dirt, etc.). At high speeds

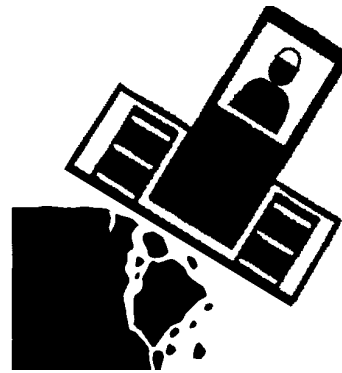
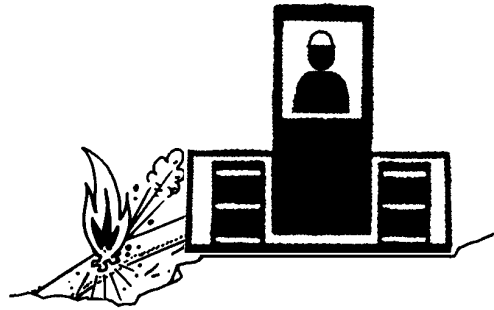

hitting obstacles (rocks, uneven concrete or manholes) can cause a sudden stop. Always wear your seat belt.

VD76477,000107A -19-26JUN09-1/1

T139002—UN—05MAR01

T139003—UN—05MAR01

Keep Riders Off Machine

Only allow operator on machine.

Riders are subject to injury. They may fall from machine, be caught between machine parts, or be struck by foreign objects.

Riders may obstruct operator's view or impair the operator's ability to operate machine safely.



Keep Riders Off Machine

TX03768,0000B73 -19-03JUN15-1/1

T137580—UN—22FEB01

Avoid Backover Accidents

Before moving machine, be sure that all persons are clear of machine path. Turn around and look directly for best visibility. Use mirrors to assist in checking all around machine. Keep windows and mirrors clean, adjusted, and in good repair.

Be certain reverse warning alarm is working properly.

Use a signal person when backing if view is obstructed or when in close quarters. Keep signal person in view at all times. Use prearranged hand signals to communicate.

Do not rely on the rear camera and radar object detection systems, if equipped, to determine if personnel are behind the machine. The system has limitations due to



maintenance practices, environmental conditions, and operating range.

TX.AVOID.BACKOVER -19-04MAR16-1/1

PC10857XW —UN—15APR13

Avoid Machine Tip Over and Machine Damage

Use seat belt at all times.

Do not jump if the machine tips. You will be unlikely to jump clear and the machine may crush you.

Load and unload from trucks or trailers carefully. Be sure truck is wide enough and secured on a firm level surface. Use loading ramps and attach them properly to truck bed. Avoid trucks with steel beds because tracks slip more easily on steel.

Be careful on slopes. Use extra care on soft, rocky, or frozen ground because machine may slip sideways in these conditions. When traveling up or down steep slopes, keep the bucket or blade on uphill side and just above ground level.

Ensure solid footing. Use extra care when operating on stockpile materials, or near banks or excavations that may cave-in and cause machine to tip or fall.

Avoid machine damage on slopes. Use extra care to operate machine.



**USE
SEAT
BELT**

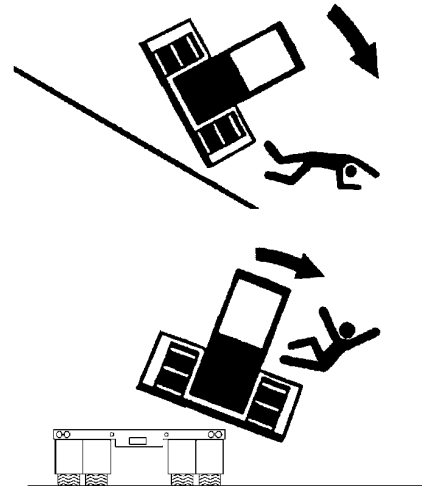

AM40430,00000B7 -19-12FEB07-1/1

T133716 —19—17APR13

T138416 —UN—22FEB01

T138415 —UN—22FEB01

Use Special Care When Operating

Never use the attachment to lift people. Do not allow anyone to ride on attachment or use it as a work platform.

Operate carefully with raised loads. Raising the load reduces machine stability, especially on side slopes or an unstable surface. Drive and turn slowly with a raised load.

Be careful when lifting loads. Never attempt to lift loads too heavy for machine. Ensure machine stability and hydraulic capability with a test lift before attempting other maneuvers. Keep bystanders away from raised loads.

DB84312,00000CA -19-21JAN16-1/1

Inspect and Maintain ROPS

A damaged rollover protective structure (ROPS) should be replaced, not reused.

The protection offered by ROPS could be impaired if ROPS is subjected to structural damage, is involved in an overturn incident, or is in any way altered by welding, bending, drilling, or cutting.

If ROPS was loosened or removed for any reason, inspect it carefully before operating the machine again.

To maintain the ROPS:

- Replace missing hardware using correct grade hardware.
- Check hardware torque.
- Check isolation mounts for damage, looseness, or wear; replace them if necessary.
- Check ROPS for cracks or physical damage.

TX,ROPS -19-20JAN11-1/1

Travel Safely

When working on steep slopes, travel as straight up and down as possible to prevent roll over.

DO NOT PARK ON A HILLSIDE OR AN INCLINE.

Always park the machine on level ground.

Know the location of bystanders before moving the machine.

Always keep the reverse/travel warning alarm in working condition. The alarm warns bystanders when the machine starts to move in reverse.

Use a signal person when moving the machine in congested areas. Coordinate hand signals before starting the machine.

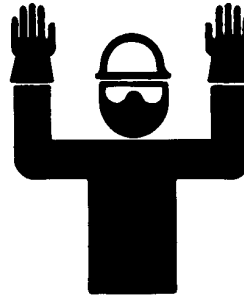

Travel Safely

T6964AD —UN—20DEC88

KR46761,00010AB -19-05FEB19-1/1

Prevent Acid Burns

Sulfuric acid in battery electrolyte is poisonous. It is strong enough to burn skin, eat holes in clothing, and cause blindness if splashed into eyes.

Avoid the hazard by:

1. Filling batteries in a well-ventilated area.
2. Wearing eye protection and rubber gloves.
3. Avoiding breathing fumes when electrolyte is added.
4. Avoiding spilling or dripping electrolyte.
5. Use proper jump start procedure.

If you spill acid on yourself:

1. Flush your skin with water.
2. Apply baking soda or lime to help neutralize the acid.
3. Flush your eyes with water for 15—30 minutes. Get medical attention immediately.

If acid is swallowed:

1. Do not induce vomiting.
2. Drink large amounts of water or milk, but do not exceed 2 L (2 quarts).
3. Get medical attention immediately.

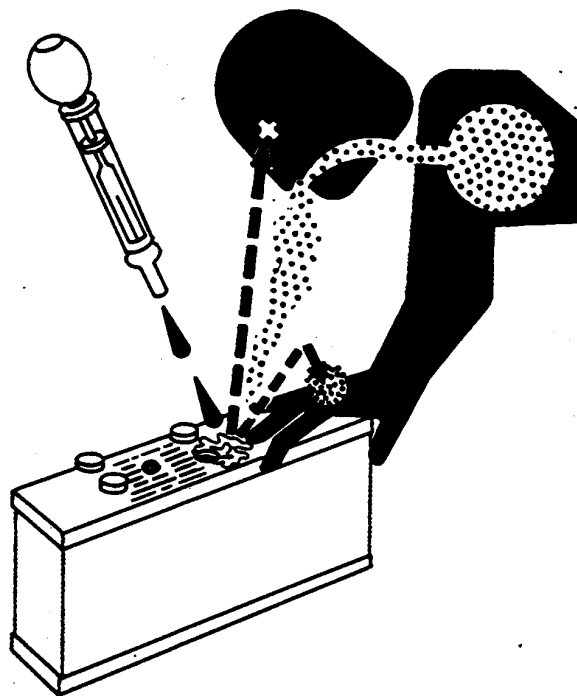

TS203—UN—23AUG88

DX,POISON -19-21APR93-1/1

Add and Operate Attachments Safely

Always verify compatibility of attachments by contacting your authorized dealer. Adding unapproved attachments could affect machine stability or reliability and could create a hazard for others near the machine.

Ensure that a qualified person is involved in attachment installation. Add guards to machine if operator protection

is required or recommended. Verify that all connections are secure and attachment responds properly to controls.

Carefully read attachment manual and follow all instructions and warnings. In an area free of bystanders and obstructions, carefully operate attachment to learn its characteristics and range of motion.

TX,ATTACH -19-20JAN11-1/1

Park and Prepare for Service Safely

Warn others of service work. Always park and prepare your machine for service or repair properly.

- Park machine on a level surface and lower blade and attachments to the ground.
- Place park lock lever(s) in “up” (locked) position. Stop engine.
- Attach a “Do Not Operate” tag in an obvious place in the operator’s station.

Securely support machine or attachment before working under it.

- Do not support machine with blade or attachments.
- Do not support machine with cinder blocks or wooden pieces that may crumble or crush.
- Do not support machine with a single jack or other devices that may slip out of place.

Understand service procedures before beginning repairs. Keep service area clean and dry. Use two people whenever the engine must be running for service work.

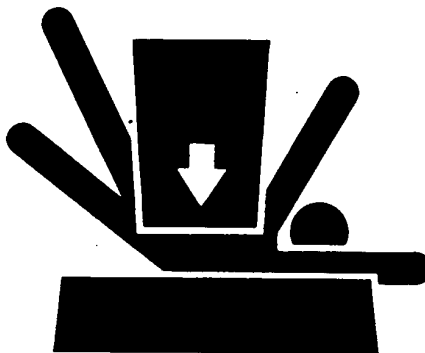

T133332—19—17APR13

TS229—UN—23AUG88

TX,PARK,CRW -19-30JAN12-1/1

Service Machines Safely

Tie long hair behind head. Do not wear a necktie, scarf, loose clothing, or necklace when working near machine tools or moving parts. If these items were to get caught, severe injury could result.

Remove rings and other jewelry to prevent electrical shorts and entanglement in moving parts.

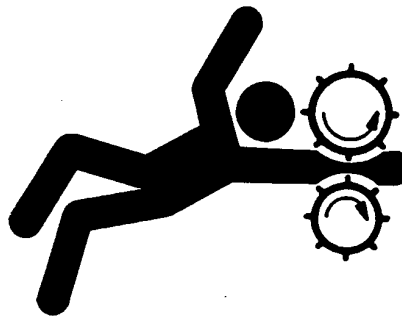

Service Machines Safely

TS228—UN—23AUG88

KR46761,00011BA -19-28JUN16-1/1

Service Cooling System Safely

Explosive release of fluids from pressurized cooling system can cause serious burns.

Do not service radiator through the radiator cap. Only fill through the surge tank filler cap. Shut off engine. Only remove surge tank filler cap when cool enough to touch with bare hands. Slowly loosen cap to relieve pressure before removing completely.

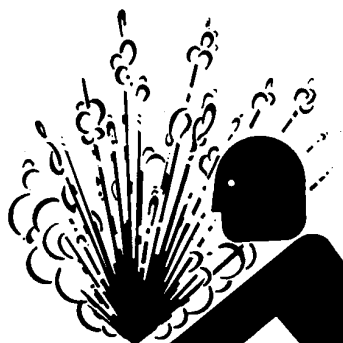

TS281—UN—15APR13

TX,SURGE -19-19JAN11-1/1

Remove Paint Before Welding or Heating

Avoid potentially toxic fumes and dust.

Hazardous fumes can be generated when paint is heated by welding, soldering, or using a torch.

Remove paint before heating:

- Remove paint a minimum of 100 mm (4 in.) from area to be affected by heating. If paint cannot be removed, wear an approved respirator before heating or welding.
- If you sand or grind paint, avoid breathing the dust. Wear an approved respirator.
- If you use solvent or paint stripper, remove stripper with soap and water before welding. Remove solvent or paint stripper containers and other flammable material from area. Allow fumes to disperse at least 15 minutes before welding or heating.

Do not use a chlorinated solvent in areas where welding will take place.

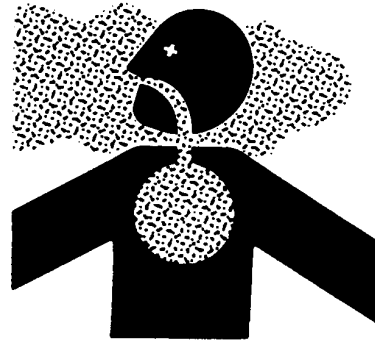

Do all work in an area that is well ventilated to carry toxic fumes and dust away.

Dispose of paint and solvent properly.

DX,PAINT -19-24JUL02-1/1

TS220 —UN—15APR13

Make Welding Repairs Safely

IMPORTANT: Disable electrical power before welding. Turn off main battery switch and disconnect positive (+) and negative (-) battery cables.

Do not weld or apply heat on any part of a reservoir or tank that has contained oil or fuel. Heat from welding and cutting can cause oil, fuel, or cleaning solution to create gases which are explosive, flammable, or toxic.

Avoid welding or heating near pressurized fluid lines. Flammable spray may result and cause severe burns if pressurized lines malfunction as a result of heating. Do not let heat go beyond work area to nearby pressurized lines.

Remove paint properly. Do not inhale paint dust or fumes. Use a qualified welding technician for structural repairs.



Heating Near Pressurized Fluid Lines

Make sure there is good ventilation. Wear eye protection and protective equipment when welding.

KR46761,00010AD -19-22JAN16-1/1

T133547 —UN—15APR13

Drive Metal Pins Safely

Always wear protective goggles or safety glasses and other protective equipment before striking hardened parts. Hammering hardened metal parts such as pins and bucket teeth could dislodge chips at high velocity.

Use a soft hammer or a brass bar between hammer and object to prevent chipping.

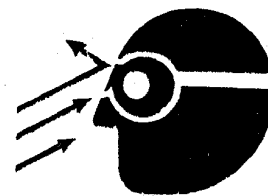

TX,PINS -19-20JAN11-1/1

T133738 —UN—15APR13

THANK YOU FOR VISITE WITH

www.repair-manuals.com

DOWNLOAD THIS FULL MANUAL

Until download and place it on your computer We care with you ,We really try our best to complete your orders, so your review is very important to us to improve our services

WE OFFER

ORIGINAL FACTORY MANUALS , WORKSHOP
MANUALS , SERVICE MANUALS , REPAIR

OUR VISION : 100 % CUSTOMER SATISFACTION,
AFTER SALE SERVICE AND KEEP IN TOUCH WITH