

BOMAG

Service - Manual

BW 24/27 RH

S/N 101 538 00 S/N 101 538 10

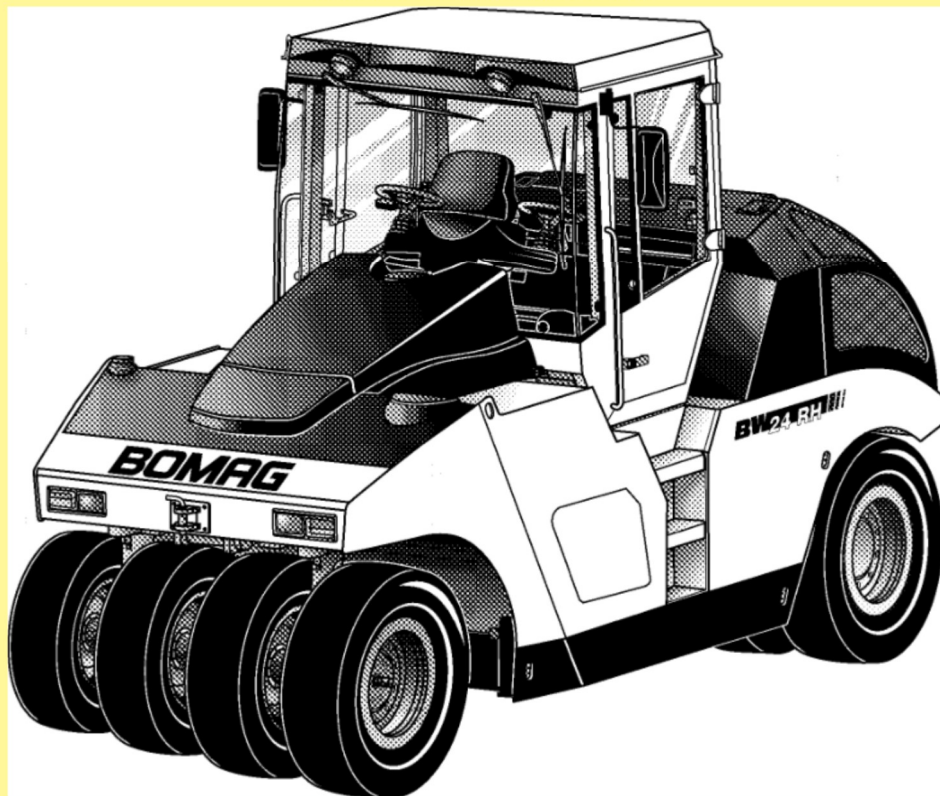

Rubber tire roller

General		7
	1.1 Introduction	8
	1.2 Safety regulations	9
	1.3 General repair instructions	14
	1.4 Tightening torques	24
Maintenance		29
	2.1 General notes on maintenance	30
	2.2 Fuels and lubricants	31
	2.3 Table of fuels and lubricants	33
	2.4 Running-in instructions	34
	2.5 Maintenance chart	35
Technical data		37
	3.1 Technical data	38
Fundamental electrics		43
	4.1 Understanding circuit diagrams	44
	4.2 Terminal designations	49
	4.3 Battery ground and analog ground	53
	4.4 Current and voltage	53
	4.5 CAN-Bus	56
	4.6 Resistance	58
	4.7 Series / parallel connection	60
	4.8 Ohm's law	62
	4.9 Electrical energy	62
	4.10 Formula diagram	63
	4.11 Metrology	64
	4.12 Diodes, relays, fuses	67
	4.13 Batteries	70
	4.14 Three-phase generator	73
	4.15 Electric starter	81
	4.16 Telemecanique switch	84
	4.17 Inductive proximity switches	87
	4.18 Angle sensors	88
	4.19 Plug connectors	90
	4.20 Deutsch plug, series DT and DTM	90
	4.21 Plugs and terminals in spring clamping technology	97
	4.22 Electric modules	100
Special tools, electrics		101
	5.1 Special tools, electrics	102
Electronic modules		111
	6.1 Module description A04	113
	6.2 Module description A100	123
Speedometer Module		133
	7.1 Speedometer module	134
Engine		137
	8.1 Diesel engine, general	138
	8.2 Service side	139

Table of Contents

8.3 Starter side	140
8.4 Compressor	141
8.5 Lubrication oil circuit	144
8.6 Oil pressure switch and low oil pressure circuitry	146
8.7 Check the engine oil level	147
8.8 Changing engine oil and oil filter cartridges	148
8.9 Coolant circuit	150
8.10 Coolant temperature switch	152
8.11 Disassembling and assembling the coolant temperature switch	153
8.12 Replacing the thermostat	154
8.13 Checking the thermostat in disassembled state	155
8.14 Check the coolant level	156
8.15 Change the coolant	156
8.16 Clean the cooling fins on engine and hydraulic oil cooler	157
8.17 Three-phase generator	158
8.18 Checking / replacing the ribbed V-belt	159
8.19 Check the engine mounts	160
8.20 Fuel supply	161
8.21 Injection system	164
8.22 Injection pump replacement during service	166
8.23 Injection valve replacement during service	174
8.24 Checking / repairing injection valves	177
8.25 Fuel filter	182
8.26 Check, clean the water separator	184
8.27 Change the fuel pre-filter cartridge	184
8.28 Change the fuel filter cartridge	185
8.29 Checking the compression	186
8.30 Check, adjust the valve clearance	187
8.31 Boost fuel solenoid valve	189
8.32 Engine shut-down solenoid	190
8.33 Air filter, differential pressure switch	191
8.34 Combustion air filter service	192
8.35 Heating flange on engine (option)	195
8.36 Checking the heating flange control	199
8.37 Engine monitoring	200
8.38 Engine	204
8.39 Special tools, Deutz engine (BFM 2012)	206
Front axle	219
9.1 Repair overview for front axle	220
9.2 Dismantling the front axle	221
9.3 Assembling the front axle	228
Service Training	251
10.1 Service Training Hydraulics	253
Air conditioning system	325
11.1 Physical basics	327
11.2 Refrigerant R134a	330
11.3 Compressor oil / refrigeration oil	331
11.4 Working principle of the air conditioning system	332

11.5 Monitoring devices	332
11.6 Description of components	333
11.7 Checking the compressor oil level	339
11.8 Checking the magnetic clutch	340
11.9 Inspection and maintenance work	341
11.10 Checking, replacing the refrigerant compressor V-belt	341
11.11 Service the air conditioning	342
11.12 Drying and evacuation	345
11.13 Emptying in case of repair	345
11.14 Leak test	346
11.15 Filling instructions	347
11.16 Trouble shooting in refrigerant circuit, basic principles	350
11.17 Trouble shooting, refrigerant circuit diagram	354
11.18 Trouble shooting procedure	355
11.19 Steam table for R134a	365
11.20 Heating control / air conditioning control	371
Replacing the cab window panes	377
12.1 Assembly of window panes	378
12.2 Special tools	379
12.3 Auxiliary materials	380
12.4 Removing and installing the window pane	382
Suppliers documentation	387
13.1 Travel pump A4VG 71 ... 180	389
13.2 Travel motor A6VM/VE	451
13.3 Travel gear	505
Circuit diagrams	579
14.1 Wiring diagram	581
14.2 Hydraulic diagram	601
14.3 Pneumatic diagram	605
Supplement to circuit diagram	609
15.1 Control elements	610
15.2 Monitoring board A15	613
15.3 Terminal box	615
15.4 Engine compartment	616

1 General

1.1 Introduction

This manual is intended to support expert mechanics in efficient repair and maintenance work. Whoever wants to do repair work himself should have been sufficiently trained and possess profound expert knowledge, he should limit his work only to those parts and components which will not affect the safety of the vehicle or the passengers. It is highly recommended to have repairs to critical systems, such as steering, brakes and travel drive, solely carried out by a BOMAG workshop. Untrained persons should NEVER UNDERTAKE SUCH REPAIR WORK.

The repair instructions describe the removal or dismantling and assembly of components and assembly groups. The repair of disassembled assembly groups is described as far as this makes sense with respect to available tools and spare parts supply and as far as it can be understood by a skilled mechanic.

Documentation

For the BOMAG machines described in this training manual the following documentation is additionally available:

- 1 **Operating and maintenance instructions**
- 2 **Spare parts catalogue**
- 3 **Wiring diagram***
- 4 **Hydraulic diagram***
- 5 **Service Information**

You should only use genuine BOMAG spare parts.

Spare parts needed for repairs can be taken from the spare parts catalogue for the machine.

This manual is not subject of any updating service; we would therefore like to draw your attention to the additionally published "technical service information".

In case of a new release all necessary changes will be included.

In the course of technical development we reserve the right for technical modifications without prior notification.

Information and illustrations in this manual must not be reproduced and distributed, nor must they be used for the purpose of competition. All rights according to the copyright law remain expressly reserved.

Danger

Please observe strictly the safety regulations in this manual, in the operating instructions as well as the applicable accident prevention regulations.

BOMAG GmbH

Printed in Germany

Copyright by BOMAG

* The applicable documents valid at the date of printing are part of this manual.

Important notes

These safety regulations must be read and applied by every person involved in the repair of this machine. The applicable accident prevention instructions and the safety regulations in the operating and maintenance instructions must be additionally observed.

Repair work shall only be performed by appropriately trained personnel or by the after sales service of BOMAG.

Any suggestions, safety precautions and warnings in this section are intended as a mnemonic aid for well trained and experienced expert mechanics. This manual should not be considered a bible on workshop safety.

Workshop equipment and facilities as well as the use and waste disposal of solvent, fluids, gases and chemicals are subject to legal regulations, which are intended to provide a minimum on safety. It is obviously your own responsibility to know and adhere to these regulations.

This manual contains headers like "Note", "Attention", "Danger" and "Environment", which must be strictly complied with in order to avoid dangers for health and for the environment.

Danger

Paragraphs marked like this highlight possible dangers for persons.

Caution

Paragraphs marked like this highlight possible dangers for machines or parts of the machine.

Note

Paragraphs marked like this contain technical information for the optimal economical use of the machine.

Environment

Paragraphs marked like this point out practices for safe and environmental disposal of fuels and lubricants as well as replacement parts.

Observe the regulations for the protection of the environment.

General

- Before starting repair work stand the machine on level and solid ground.
- Always secure the machine against unintended rolling.
- Secure the engine reliably against unintentional starting.

- Mark a machine that is defective or being repaired by attaching a clearly visible warning tag to the steering wheel.
- On machines with articulated joint keep the articulated joint locked during work.
- Use protective clothes like hard hat, safety boots and gloves.
- Keep unauthorized persons away from the machine during repair work.
- Tools, lifting gear, lifting tackle, supports and other auxiliary equipment must be fully functional and in safe condition.
- Use only safe and approved lifting gear of sufficient load bearing capacity to remove and install parts or components from and to the machine.
- Be careful with cleansing agents. Do not use easily inflammable or harmful substances, such as gasoline or paint thinners for cleaning.
- Cleaning or repair work on the fuel tank is very dangerous. Do not smoke or allow any ignitable sparks or open fire in the vicinity when cleaning or repairing a tank.
- When performing welding work strictly comply with the respective welding instructions.

Precautions and codes of conduct for welding work

Welding work should only be performed by specially instructed expert personnel.

Danger

Electric shock!

Sparks, fire hazard, burning of skin!

Infrared or ultraviolet radiation (arc), flashing of eyes!

Health hazard caused by welding work on highly alloyed work pieces, metal coatings, paint coatings, plastic coatings, oil containing dirt deposits, grease or solvent residues, etc.!

- Check welding equipment and cables for damage before use (also the validity of inspection stickers).
- Ensure good conductivity between earth cable and work piece.
- Start the extraction fan before starting work and guide with the progressing work as required.
- Always isolate the burner when laying it down (remove possible electrode residues).
- Protect cables from being damaged, use cables with insulated couplings.
- Ensure sufficient fire protection, keep a fire extinguisher at hand.

- In case of welding work in fire or explosion endangered environments, you should always ask for a welding permission.
- Remove combustible parts from the vicinity or cover such parts.
- Name a fire watch during and after welding work.
- Do not clamp the welding rod holder and the inert gas welding gun under your arm and lay these parts only on an insulated top.
- Place the inert gas bottles in a safe place and secure them against falling over.
- Use a protective screen or an arcing shield with welding glass, wear welding gloves and clothes, this applies also for assisting persons.
- Switch the welding unit off before connecting welding cables.

Behaviour in case of faults

- Check electrode holders and electric cables at regular intervals.
- In case of deficiencies switch off the welding unit and inform supervising persons.
- In case of an extractor fan failure or any other fault inform the supervising persons.

Maintenance; waste disposal

- Replace damaged insulating jaws and welding rod holders immediately.
- Replace the welding wire reels only in deenergized state.

What to do in case of accidents; First Aid

- Keep calm.
- Call first air helpers.
- Report the accident.
- In case of an electric accident: Interrupt the power supply and remove the injured person from the electric circuit. If breathing and heart have stopped apply reactivation measures and call for an emergency doctor.

Old oils

Prolonged and repetitive contact with mineral oils will remove the natural greases from the skin and causes dryness, irritation and dermatitis. Moreover, used engine oils contain potentially hazardous contaminants, which could cause skin cancer. Appropriate skin protection agents and washing facilities must therefore be provided.

- Wear protective clothes and safety gloves, if possible.
- If there is a risk of eye contact you should protect your eyes appropriately, e.g. chemistry goggles or

full face visor; a facility suitable for rinsing the eyes should also be available.

- Avoid prolonged and repetitive contact with oil, especially with old oil. In case of open incisions and injuries seek medical advice immediately.
- Apply protective cream before starting work, so that oil can be easier removed from the skin.
- Wash with soap and water to ensure that all oil has been removed (a skin cleaning agent and a nail brush will help). Lanolin containing agents will replace natural skin oils that were lost.
- Do not use gasoline, kerosene, diesel, thinner or solvents to wash the skin.
- Do not put oil soaked cloths into your pockets.
- Avoid clothes, especially underpants, getting soiled by oil.
- Overalls must be washed at regular intervals. Clothes that cannot be washed, must be disposed of.
- If possible degrease components before handling.

Environment

It is strictly prohibited to drain off oil into the soil, the sewer system or into natural waters. Entrust special companies with the waste disposal of old oil. If in doubt you should consult your local authorities.

Hydraulics

- Hydraulic oil escaping under pressure can penetrate the skin and cause severe injury. You should therefore relieve the pressure in the system before disconnecting any lines.
- Before applying pressure to the system make sure that all line connections and ports have been properly tightened and are in perfect condition.
- Hydraulic oil leaking out of a small opening can hardly be noticed, therefore please use a piece of cardboard or wood when checking for leaks. When being injured by hydraulic oil consult a physician immediately, as otherwise this may cause severe infections.
- Do not step in front of or behind the drums/wheels/crawler tracks when performing adjustment work in the hydraulic system while the engine is running. Block drums and/or wheels / crawler tracks with wedges.

Reattach all guards and safety installations after all work has been completed.



Environment

It is strictly prohibited to drain off hydraulic oil into the soil, the sewer system or into natural waters. Entrust special companies with the waste disposal of old oil. If in doubt you should consult your local authorities.

Fuels



Danger

Repair work on fuel systems must only be performed by appropriately trained personnel.

The following notes refer to general safety precautions for danger free handling of fuel. These notes are only general instructions; in case of uncertainties you should consult the person responsible for fire protection.

Fuel vapours not only are easily inflammable, but also highly explosive inside closed rooms and toxic; dilution with air creates an easily inflammable mixture. The vapours are heavier than air and therefore sink down to the ground. Inside a workshop they may easily become distributed by draft. Even the smallest portion of spilled fuel is therefore potentially dangerous.

- Fire extinguishers charged with FOAM, SCHAUM, CO₂ GAS or POWDER must be available wherever fuel is stored, filled in, drained off, or where work on fuel systems is performed.
- The vehicle battery must always be disconnected, BEFORE work in the fuel system is started. While working on the fuel system you should not disconnect the battery, because this could generate sparks, which would ignite explosive fuel vapours.
- Wherever fuel is stored, filled, drained off or where work on fuel systems is carried out, all potential ignition sources must be extinguished or removed. Search lights must be fire proof and well protected against possible contact with running out fuel.

Hot fuels

Before draining fuel off the tank for repair work, you must strictly apply the following measures:

- Allow the fuel to cool down, to prevent any contact with a hot fluid.
- Vent the system, by removing the filler cap in a well ventilated area. Screw the filler cap back on, until the tank is finally emptied.

Synthetic rubber

Many O-rings, hoses and similar parts, which are apparently made of natural rubber, are actually made of

plastic material, a so-called fluoroelastomer. Under normal operating conditions this material is safe and does not impose any danger to health.

However, if this material becomes damaged by fire or extreme heat, it may decompose and form highly caustic hydrofluoric acid, which can cause severe burns in contact with skin.

- If the material is in such a state it must only be touched with special protective gloves. These gloves must be disposed of directly after use.
- If the material has contacted the skin despite these measures, take off the soiled clothes and seek medical advice immediately. In the meantime wash the affected parts of the skin for 15 to 60 minutes with cold water or lime water.

Poisonous substances

Some of the fluids and substances used are toxic and must under no circumstances be consumed.

Skin contact, especially with open wounds, should be strictly avoided.

These fluids and substances are, amongst others, anti-freeze agents, hydraulic oils, washing additives, lubricants and various bonding agents.

Engine



Danger

Do not work on the fuel system while the engine is running - danger to life!

After the engine has stopped wait until the pressure has dropped (on Common Rail engines approx. 5 minutes, other engines 1 minute), because the system is under high pressure - danger to life!

Keep out of the danger zone during the initial test rung. Danger caused by high pressure in case of leaks - danger to life!

When performing work on the fuel system make sure that the motor cannot be started unintentionally - danger to life!

- Maintenance and cleaning work on the engine must only be performed with the engine stopped and cooled down. Make sure that the electric system has been switched off (ignition key pulled out).
- Observe the accident prevention regulations for electric systems (e.g. -VDE-0100/-0101/-0104/-0105 Electric precautions against dangerous contact voltages).
- Cover all electric components properly before wet cleaning.

Air conditioning system

Caution

Lines in the air conditioning system must only be loosened by trained and explicitly instructed experts.

- Wear safety goggles! Put on your safety goggles. This will protect your eyes against coming into contact with refrigerant, which could cause severe damage by freezing.
- Wear safety gloves and an apron! Refrigerant are excellent solvents for greases and oils. In contact with skin they will remove the protective grease film. However, degreased skin is very sensitive against cold temperatures and germs.
- Do not allow liquid refrigerants to come into contact with skin! Refrigerant takes the heat required for evaporation from the environment. Very low temperatures may be reached. The results may be local frost injuries (boiling point of R134a -26.5°C at ambient pressure).
- Do not inhale higher concentrations of refrigerant vapours! Escaping refrigerant vapours will mix with the ambient air and displace the oxygen required for breathing.
- Smoking is strictly prohibited! Refrigerants may be decomposed by a glowing cigarette. The resulting substances are highly toxic and must not be inhaled.
- Welding and soldering on refrigeration equipment! Before starting welding or soldering work on vehicles, (in the vicinity of air conditioning components) all refrigerant must be drawn out and the rests removed by blowing out the system with nitrogen. The decomposition products created from the refrigerant under the influence of heat not only are highly toxic, but also have a strong corrosive effect, so that pipes and system components may be attacked. The substance is mainly fluorohydrogen.
- Pungent smell! In case of a pungent smell the aforementioned decomposition products have already been created. Extreme care must be exercised not to inhale these substances, as otherwise the respiratory system, the lungs and other organs may be harmed.
- When blowing out components with compressed air and nitrogen the gas mixture escaping from the components must be extracted via suitable exhaust facilities (workshop exhaust systems).

Handling pressure vessels

- Since the fluid container is pressurized, the manufacture and testing of these pressure vessels is governed by the pressure vessel directive. (New edition

from April 1989). Paragraph 10 of the pressure vessel directive demands that these pressure containers must be periodically inspected and tested by a specialist, according to paragraph 32. In this case periodically recurring inspections consist of external examinations, normally on containers in operation. The refrigerant container must be visually inspected two times per year, within the frame work of major inspections. Special attention must thereby be paid to signs of corrosion and mechanical damage. If the container is in no good condition, it should be replaced for safety reasons, in order to protect the operator or third parties against the dangers when handling or operating pressure vessels.

- Secure pressure vessels against tipping over or rolling away.
- Do not throw pressure vessels. Pressure vessels may thereby be deformed to such an extent, that they will crack. The sudden evaporation and escape of refrigerant releases excessive forces. This applies also when snapping off valves on bottles. Bottles must therefore only be transported with the safety caps properly installed.
- Refrigerant bottles must never be placed near heating radiators. Higher temperatures will cause higher pressures, whereby the permissible pressure of the vessel may be exceeded. The pressure vessel directive therefore specifies that a pressure vessel should not be warmed up to temperatures above 50°C .
- Do not heat up refrigerant bottles with an open flame. Excessive temperatures can damage the material and cause the decomposition of refrigerant.
- Do not overfill refrigerant bottles, since any temperature increase will cause enormous pressures.

Environment

In operation, during maintenance and repair work and when taking refrigeration systems out of service it is not permitted to let refrigerant escape into the atmosphere, which would contradict the current status of technology.

Battery

- Wear goggles and face protection (acid).
- Wear suitable clothes to protect face, hands and body (acid).
- Work and store accumulators only well ventilated rooms. (Development of oxyhydrogen gas).
- Do not lean over the battery while it is under load, being charged or tested. (Danger of explosion).
- Burning cigarettes, flames or sparks can cause explosion of the accumulator
- Keep ignition sources away from the battery.

- Always shield eyes and face towards the battery.
- Do not use battery chargers or jump leads without following the operating instructions.
- Keep the cell plugs closed.
- After an accident with acid flush the skin with water and seek medical advice.
- Do not allow children access to batteries.
- When mixing battery fluid always pour acid into water, never vice-versa.
- There is a danger of scalding when draining off engine or hydraulic oil at operating temperature.
- on machines with rubber tires a tire may burst if incorrectly assembled. This can cause severe injury.
- Do not exceed the specified highest permissible tire pressure.

Special safety regulations

- Use only genuine BOMAG spare parts for repair purposes. Original parts and accessories have been specially designed for this machine.
- We wish to make explicitly clear that we have not tested or approved any parts or accessories not supplied by us. The installation and/or use of such products may therefore have an adverse effect on the specific characteristics of the machine and thereby impair the active and/or passive driving safety. The manufacturer explicitly excludes any liability for damage caused by the use of non-original parts or accessories.
- Unauthorized changes to the machine are prohibited for safety reasons.
- If tests on the articulated joint need to be performed with the engine running, do not stand in the articulation area of the machine, danger of injury!
- Do not perform cleaning work while the engine is running.
- If tests must be performed with the engine running do not touch rotating parts of the engine, danger of injury.
- Exhaust gases are highly dangerous. Always ensure an adequate supply of fresh air when starting the engine in closed rooms.
- Refuel only with the engine shut down. Ensure strict cleanliness and do not spill any fuel.
- Keep used filters in a separate waste container and dispose of environmentally.
- Dispose of oils and fuel environmentally when performing repair or maintenance work.
- Do not refuel in closed rooms.
- Do not heat up oil higher than 160 °C because it may ignite.
- Wipe off spilled oil and fuel.
- Do not smoke when refuelling or when checking the acid level in the battery.
- Do not check the acid level of the battery with a naked flame, danger of explosion!
- Old batteries contain lead and must be properly disposed of.

General

- Before removing or disassembling and parts, hoses or components mark these parts for easier assembly.
- Before assembly oil or grease all parts, as far as this is necessary.

Electrics

General

The electric and electronic systems in construction equipment are becoming more and more extensive. Electronic elements are increasingly gaining importance in hydraulic and mechanical vehicle systems.

Diagnostics according to plan

A structured approach in trouble shooting saves time and helps to avoid mistakes and expenses, especially in the fields of electrics and electronics. Understanding electronic controls requires the knowledge of some basic terms concerning their general performance. In many cases error logs are just simply read out and control units are replaced without any further trouble shooting. This is in most cases unnecessary and, even more important, very expensive.

Random tests have revealed that purely electronic components or control units only very rarely are the actual cause of failures:

- In approx. 10 % of the examined cases the problems were caused by control units.
- In approx. 15 % sensors and actuators were the cause of the problems.

By far the highest proportion of all faults could be traced back to wiring and connections (plugs, etc.).

General:

- Before changing any expensive components, such as control units, you should run a systematic trouble shooting session to eliminate any other possible fault sources. Electric signals must be checked at the locations to which they are applied, i.e. on control unit or sensor technology. So, if the system had been diagnosed without unplugging the control unit and checking the wiring, one should be alerted.
- Check for good cable and ground contacts, therefore keep all mechanical transition points between electric conductors (terminals, plugs) free of oxide and dirt, as far as this is possible.
- Perform trouble shooting in a systematic way. Do not become confused by the high number and variety of electric cables, current can only flow in a closed circuit. You should first become acquainted with the function of the corresponding electric circuit by following the correct wiring diagram. Detected faults should be rectified immediately. If the system still does not work correctly after this measure, trouble shooting must be continued. Several faults very rarely occur at the same time, but it is not impossible.
- Do not disconnect or connect battery or generator while the engine is running.
- Do not operate the main battery switch under load.

- Do not use jump leads after the battery has been removed.
- Sensors and electric actuators on control units must never be connected individually or between external power sources for the purpose of testing, but only in connection with the control unit in question, as otherwise there may be a risk of destruction (damage)!
- Disconnecting the control unit plug connectors with the control unit switched on, i.e. with the power supply (terminal 15 "On"), is not permitted. Switch the voltage supply "off" first - then pull out the plug.
- Even with an existing polarity reversal protection incorrect polarity must be strictly avoided. Incorrect polarity can cause damage to control units!
- Plug-in connectors on control units are only dust and water tight if the mating connector is plugged on! Control units must be protected against spray water, until the mating connector is finally plugged on!
- Unauthorized opening of the control electronics (micro controller MC) as well as changes or repairs on the wiring can lead to dangerous malfunctions.
- Do not use any radio equipment or mobile phones inside the driver's cab without an appropriate outside antenna or in the vicinity of the control electronics!

Electrical system and welding work

- Surge voltages in the electric system must be strictly avoided:
- When performing welding work always fasten the earth clamp of the welding unit in the immediate vicinity of the welding location.

Caution

Switch off the main battery switch, disconnect the generator and pull the plug out on the control unit before starting welding work.

Battery

Rules for the handling of batteries

Even though it may be conveniently installed in the engine compartment, it should never be used as a rest for tools. When connecting the poles, e.g. by means of a spanner, the battery will become an "electric welder".

As a measure to avoid short circuits you should first disconnect the negative pole during disassembly and reconnect the negative pole last during assembly.

Terminal clamps should be assembled with as little force as possible.

Poles and terminal clamps should always be kept clean to avoid transition resistances during starting and the related development of heat.

You should obviously also pay attention to secure fastening of the battery in the vehicle.

Hydraulic system

Caution

Do not open any hydraulic components if you have not been properly trained and without exact knowledge.

Please note

Cleanliness is of utmost importance. Make sure that no dirt or other contaminating substances can enter into the system.

- Clean fittings, filler covers and the area around such parts before disassembly to avoid entering of dirt.
- Before disconnecting hoses, pipes or similar relieve the system pressure with the engine shut down.
- During repair work keep all openings closed with clean plastic plugs and caps.
- Do not run pumps and motors without oil.
- When cleaning hydraulic components take care not to damage any fine machine surfaces.
- Chemical and rubber soluble cleansing agents may only be used to clean metal parts. Do not let such substances come in contact with sealing material.
- Rinse of cleaned parts thoroughly, dry them with compressed air and apply anti-corrosion oil immediately. Do not install parts that show traces of corrosion.
- Avoid the formation of rust on fine machined caused by hand sweat.
- Grease must not used as a sliding agent for assembly work. Use hydraulic oil.
- Do not start the engine after the hydraulic oil has been drained off.
- Use only the specified pressure gauges. Risk of damaging the pressure gauges under too high pressure.
- Clean ports and fittings before removal so that no dirt can enter into the hydraulic system.
- Check the hydraulic oil level before and after the work.
- Use only clean oil according to specification.
- Check the hydraulic system for leaks, find and rectify the cause.
- Fill new hydraulic units with hydraulic oil before starting operation.
- After changing a component thoroughly flush and bleed the entire hydraulic system.
- Perform measurements at operating temperature of the hydraulic oil (approx. 40 °C).

- After changing a component perform a high and charge pressure test, if necessary check the speed of the exciter shaft.
- The operating pressure of the exciter shaft to a great extent depends on the base under the vibrating drum. If the soil is too hard place the drums on old rubber tires. Do not activate the vibration on a hard, concreted base, danger of bearing damage.
- After the completion of all tests perform a test run and then check all connections and fittings for leaks with the engine still stopped and the hydraulic system depressurized.

Before commissioning

- After changing a component clean the hydraulic oil tank thoroughly.
- Fill the housings of hydraulic pumps and motors with hydraulic oil.
- Use only hydraulic oils according to the specification in the maintenance instructions.
- After changing a component clean the hydraulic system as described in the flushing instructions in order to prevent all other components from being damaged by abrasion and metal chips remaining in the system.
- Change the hydraulic oil filter.

Commissioning

- Bleed the hydraulic circuits.
- Start up the system without load.
- Check the hydraulic oil level in the tank, fill up oil if necessary.

After commissioning

- Check system pressures and speeds.
- Check fittings and flanges for leaks.
- After each repair check all adjustment data, rotational speeds and nominal values in the hydraulic system, adjust if necessary.
- Do not adjust pressure relief valves and control valves to values above their specified values.

Air conditioning system

CFC - halon prohibition

The CFC - halon prohibition from May 06, 1991 regulates the withdrawal from the use of CFC and the handling of these refrigerants.

Contents:

Since 1995 CFC (R12) is no longer permitted for use in new systems.

In operation, during maintenance and repair work and when taking refrigeration systems out of service it is not permitted to let refrigerant escape into the atmosphere, which would contradict the current status of technology.

Work on refrigeration systems must only be carried out by persons with well founded knowledge about such systems and who have the necessary technical equipment available.

The use of refrigerant must be documented.

Old systems should be converted to refrigerants harmless to ozone (refrigerant substitutes).

For this reason the Federal Environmental Agency at the end of 1995 published suitable replacement refrigerants for R 12. As a consequence old systems must no longer be filled with R12. As soon as such a system is opened for service, the system must be converted to a suitable replacement or service refrigerant. Old systems may still be used, as long as they are leak tight. R 134a was nominated as replacement for R 12.

Inside the European Union the "EU-Directive 2037/2000 on substances causing decomposition of the ozone layer" regulates the production, use and availability of CFC and H-CFC.

- In case of a repair on the refrigeration system you should first evacuate the air conditioning system for at least 45 minutes to remove any moisture from the system, before you start to refill. Moisture bonded in the compressor oil / refrigeration oil (PAG oil) can only be removed from the system by changing the oil.
- During repair work on refrigerant lines and components, these must be kept closed as far as possible, in order to prevent the invasion of air, moisture and dirt, because the operational reliability of the system can only be assured if all components in the refrigerant circuit are clean and dry from inside.
- Make sure that no dirt or foreign parts can enter into the compressor or the air conditioning system. The area around the refrigerant hoses should be cleaned with a gasoline free solvent.
- All parts to be reused should be cleaned with a gasoline free solvent and blow-dried with clean compressed air or dried with a lint-free cloth.
- Before opening all components should have warmed up to ambient temperature, to avoid that damp air is drawn into the component by the difference in temperatures.
- Damaged or leaking parts of the air conditioning must not be repaired by welding or soldering, but must generally be replaced.
- Do not fill up refrigerant, but extract existing refrigerant and refill the system.
- Different types of refrigerant must not be mixed. Only the refrigerant specified for the corresponding air conditioning system must be used.
- Refrigerant circuits with refrigerant type R134a must only be operated with the compressor oil / refrigeration oil approved for the compressor.
- Used compressor oil / refrigeration oil must be disposed of as hazardous waste.
- Due to its chemical properties compressor oil / refrigeration oil must never be disposed of together with engine or transmission oil.
- Compressor oil / refrigeration oil is highly hygroscopic. Oil cans must strictly be kept closed until use. Oil rests should not be used, if the can had been opened over a longer period of time.
- All O-rings as well as pipe and hose fittings must be oiled with compressor/refrigeration oil before assembly.
- When replacing a heat exchanger, e.g. evaporator or condenser, any compressor oil / refrigeration oil lost by exchanging the components, must be replaced with fresh oil.
- A too high compressor oil / refrigeration oil level adversely affects the cooling performance and a too low oil level has a negative effect on the lifetime of the compressor.
- If a air conditioning unit needs to be opened, the dryer must be replaced in any case.
- Always use new O-rings when reassembling the unit.
- Always use two spanners when connecting pipes or hoses, to prevent the pipe end from being damaged
- Tighten screw fittings with the specified torque.
- Check the connections of pipes, fittings or components thoroughly; do not use if damaged.
- Do not leave the refrigerant circuit unnecessarily open to the atmosphere. Do not attempt to repair bent or burst pipes.
- Compressor valves must only be opened after the system has been properly sealed.
- The use of leak detection colouring matter is not permitted, because its chemical composition is unknown and its effect on compressor oil and rubber elements is not predictable. The use of leak detec-

tion colouring matter makes any warranty claims null and void.

- Tools used on refrigeration circuits must be of excellent condition, thus to avoid the damage of any connections.
- The dryer is to be installed last, after all connections in the refrigerant circuit have been tightened.
- After completion of repair work screw locking caps (with seals) on all connections with valves and on the service connections. Start up of the air conditioning system. Observe the filling capacity.
- Before start up of the air conditioning system after a new filling: - Turn the compressor approx. 10 revolutions by hand using the clutch or V-belt pulley of the magnetic clutch. - Start the engine with the compressor/control valve switched off. - Once the idle speed of the engine has stabilized switch on the compressor and run it for at least 10 minutes at idle speed and maximum cooling power.
- Never operate the compressor over longer periods of time with high engine speeds without a sufficient amount of refrigerant in the system. This could probably cause overheating and internal damage.

Fuel hoses

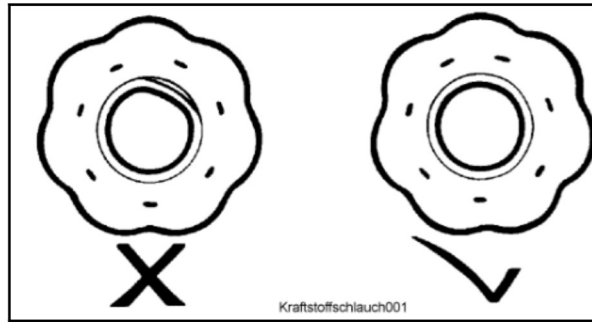

Fig. 1

⚠ Caution

All fuel hoses have two layers of material, a reinforced rubber coating outside and an internal Viton hose. If a fuel hose has come loose one must make absolutely sure that the internal Viton layer has not been separated from the reinforced outer layer. In case of a separation the hose needs to be replaced.

Gaskets and mating surfaces

Leaking or failing seals and gaskets can in most cases be tracked down to careless assembly, causing damage not only to the seal or gasket, but also to the mating surfaces. Careful assembly work is mandatory if good results are to be achieved.

- Before assembling replacement seals make sure that the running surface is free of pitting, flutes, corrosion or other damage.
- Inappropriately stored or handled seals (e.g. hanging from hooks or nails) must under no circumstances be used.
- Sealing compound should only be used if specially requested in the instructions. In all other cases these joints should be assembled in dry condition.
- Sealing compound must be applied thin and evenly on the corresponding surfaces; take care that the compound does not enter into oil galleries or blind threaded bores.
- Before assembly remove any residues of old sealing compound. Do not use any tools that could damage the sealing surfaces.
- Examine the contact faces for scratches and burrs, remove these with a fine file or an oilstone; take care that no grinding dust and dirt enters into tapped bores or enclosed components.
- Blow lines, ducts and gaps out with compressed air, replace any O-rings and seals that have been dislodged by the compressed air.

Assembly of radial seals

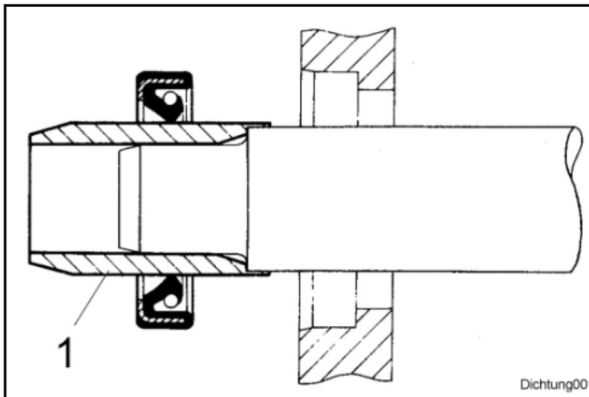

Fig. 2

- Lubricate sealing lips 1 (Fig. 2) with clean grease; in case of double seals fill the space between the sealing lips with a generous amount of grease.
- Slide the seal over the shaft, with the lip facing towards the fluid to be sealed.

i Note

If possible, use an assembly sleeve 1 (Fig. 2), to protect the lip from being damaged by sharp edges,

threads or splines. If no assembly sleeve is available, you should use a plastic tube or adhesive tape to prevent the sealing lip from being damaged.

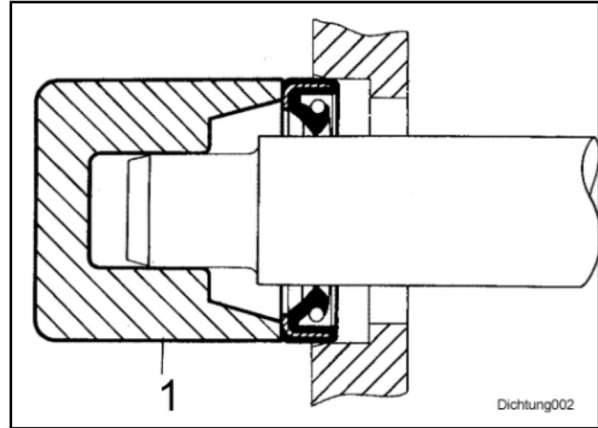

Fig. 3

- Lubricate the outer rim 1 (Fig. 3) of the seal and press it flat on the housing seat.

i Note

If possible, use a "bell" 1 (Fig. 3), to make sure that the seal will not skew. In some cases it may be advisable to assemble the seal into the housing first, before sliding it over the shaft. Under no circumstances should the full weight of the shaft rest on the seal.

If you have no proper service tools at hand, use a suitable drift punch with a diameter which is about 0.4mm smaller than the outer diameter of the seal. Use VERY LIGHT blows with the hammer if no press is available.

- Press or knock the seal into the housing, until it is flush with the housing surface.

Feather keys and keyways

⚠ Caution

Feather keys must only be reused if they show no differences to new feather keys, any notches must be considered as initial signs of wear.

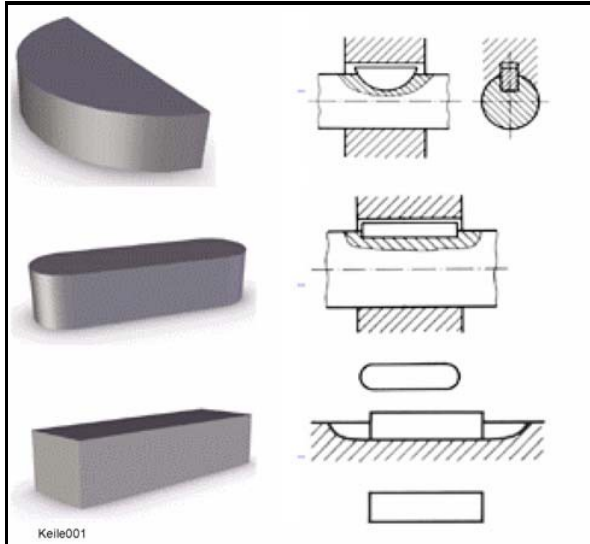

Fig. 4

- Clean and thoroughly examine the feather key.
- Debur and thoroughly clean the edges of the keyway with a fine file before reassembling.

Ball and roller bearings

⚠ Caution

Ball and roller bearings must only be reinstalled after it has been assured that they are in perfect condition.



Fig. 5

- Remove any lubricant residues from the bearing to be examined by washing it with gasoline or any other appropriate degreasing agent. Cleanliness is of utmost importance for all related work.
- Check balls or rollers, running surfaces, outer faces of outer races and inner faces of inner races for visible damage. If necessary replace the bearing with a new one, since these symptoms are first signs of wear.
- Hold the bearing with you thumb and the index finger by the inner race, rotate the outer race and make sure that it runs without friction. Hold the bearing by the outer race and repeat this test with the inner race.
- Move the outer race gently to and fro while holding it by the inner race; check for resistance while rotating and replace the bearing if it does not work correctly.
- Lubricate the bearing with an appropriate lubricant before reinstalling.

- Check shaft and bearing housing for discolouration or other signs of movement between bearing and seats.
- Make sure that shaft and housing are free of burrs before assembling the bearing.
- If a bearing of a pair of bearings shows any defects, we highly recommend the replacement of both bearings.
- On greased bearings (e.g. wheel bearings) fill the space between bearing and outer seal with the recommended type of grease before assembling the seal.
- Always mark the individual parts of separable bearings (e.g. taper roller bearings) to enable correct re-assembling. Never assemble the rollers to an outer race that has already been used, replace the complete bearing instead.

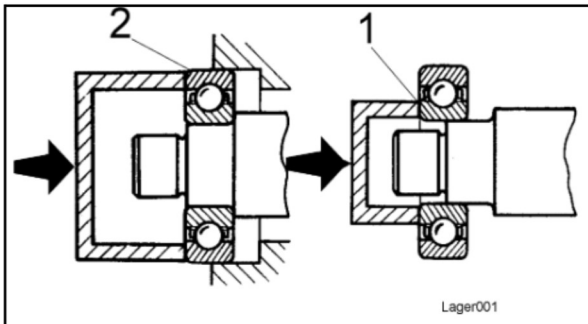

Fig. 6

⚠ Caution

When assembling the bearing to the shaft load must only be applied to the inner race 1 (Fig. 6).

When fitting the bearing into the housing load must only be applied to the outer race (2).

Screws and nuts

Tightening torque

⚠ Caution

Always tighten nuts or screws to the specified tightening torque. Tightening torques deviating from the ones in the table are specially mentioned in the repair instructions.

Damaged screws must under no circumstances be used any longer. Recutting threads with thread cutters or taps adversely affects the strength and leak tightness of the screw joint. Damaged or corroded thread pitches can cause incorrect torque value readings.

Self-locking nuts must be generally renewed.

The use of screws with too high strength can cause damage!

- Nut of a higher strength can generally be used instead of nuts of a lower strength classification.
- When checking or retightening screw joints to the specified tightening torque you should first relieve by a quarter turn and then tighten to the correct torque.
- Before tightening you should lightly oil the thread, in order to ensure low friction movement. **The same applies for self-locking nuts.**
- Make sure that no oil or grease will enter into tapped bores. The hydraulic power generated when turning in the screw could cause breakage of the effected part.

Strength classes of metric screws

The strength classes (from 3.6 to 12.9) are specified for all strength classes from a nominal diameter of 5mm. The corresponding identification can be found where allowed for by the shape of the screw.

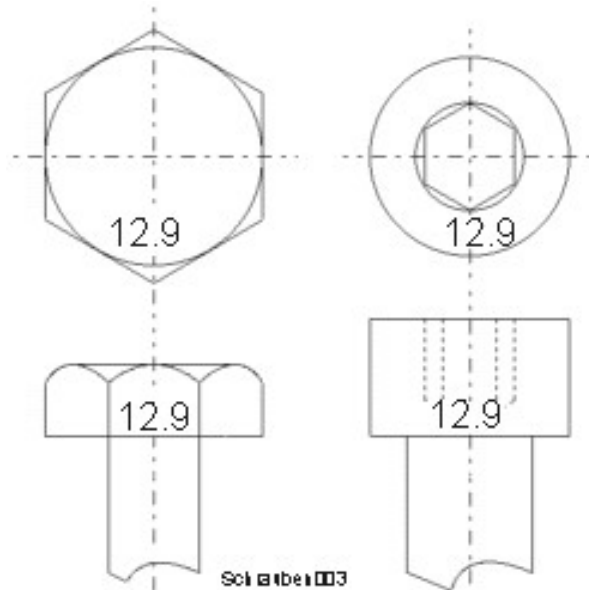

Fig. 7 Identification of screws

Example: A screw is identified with 12.9.

The first number corresponds with 1/100 of the nominal tensile strength (minimum tensile strength) in N/mm².

- The nominal tensile strength is $12 \times 100 \text{ N/mm}^2 = 1200 \text{ N/mm}^2$.

The second number specifies 10-times the ration between lower yield point and nominal tensile strength (yield point ratio).

i Note

When exceeding the lower yield point, the material will return to its original shape when being relieved (plastic deformation).

When exceeding the upper yield point the material will not restore its original shape after being relieved.

- The lower tensile strength is $9/10 \times 1200 \text{ N/mm}^2 = 1080 \text{ N/mm}^2$.

i Note

However, these values are by no means identical with the tightening torques, which are to be set on a torque wrench. The corresponding calculation requires a higher effort and, in the end, depends on the materials to be bolted together.

Strength classes of metric nuts

Nuts are differentiated by three load groups. Each load group has a special designation system for the strength class assigned, so that the load group can be clearly identified.

Nuts for screw joints with full load capability (4, 5, 6, 8, 10, 12)

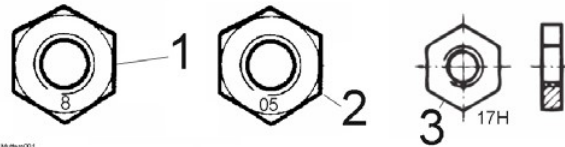

Fig. 8 Identification of nuts

In a connection with a screw, these nuts 1 (Fig. 8) must be able to bear the full pre-load at the yield point.

Nut height above 0.8 d (d = nominal dimension).

Strength class of nut	Strength class of associated screw
4	3.6, 4.6, 4.8
5	3.6, 4.6, 4.8 5.6, 5.8
6	6.8
8	8.8
9	9.8
10	10.8
12	12.8

Nuts for screw joints with limited load factor (04, 05)

The preceding "0" indicates that, due to their low height, nuts 2 (Fig. 8) in this group are only able to withstand the force of a screw to a limited extent.

Nut height below 0.8 d (d = nominal dimension).

Nuts for screw joints without specified load factor (11H, 14H, 17H, 22H)

This standard contains strength classes (hardness classes) for nuts 3 (Fig. 8), for which no load values can be specified, e.g. because of their shape and dimensions, but which can only be classified by their hardness.

Nut height below 0,5 d (d = nominal dimension).

Identification in clock system

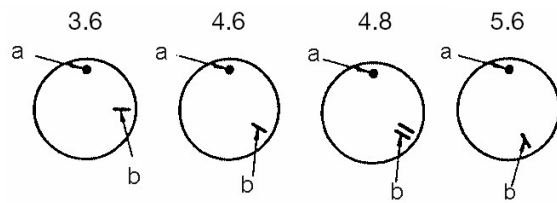

Fig. 9 Identification of nuts in clock system

For small nuts (Fig. 9) the clock system can be used for identification.

- The 12 o'clock position is identified by a dot or the manufacturer's symbol.
- The strength class is identified by a dash (b).

The values specified in the table apply for screws:

- black oiled
- with surface protection A4C
- with surface protection DACROMET

i Note

DACROMET is a surface protection that mainly consists of zinc and aluminium in a chromium oxide matrix. DACROMETIZATION provides excellent corrosion protection for metal surfaces by applying a mineral coating with metallic-silver appearance.

Tightening torques for screws with metric unified thread¹

Screw dimension	Tightening torques Nm		
	8.8	10.9	12.9
M4	3	5	5
M5	6	9	10
M6	10	15	18
M8	25	35	45
M10	50	75	83
M12	88	123	147
M14	137	196	235
M16	211	300	358
M18	290	412	490
M20	412	578	696
M22	560	785	942
M24	711	1000	1200
M27	1050	1480	1774
M30	1420	2010	2400

¹ Coefficient of friction μ tot. = 0,14

Tightening torques for screws with metric unified fine thread¹

Screw dimension	Tightening torques Nm		
	8.8	10.9	12.9
M8 x 1	26	37	48
M10 x 1.25	52	76	88
M12 x 1,25	98	137	126
M12 x 1.5	93	127	152
M14 x 1.5	152	216	255
M16 x 1.5	225	318	383
M18 x 1.5	324	466	554
M20 x 1.5	461	628	775
M22 x 1.5	618	863	1058
M24 x 2	780	1098	1294
M27 x2	1147	1578	1920
M30 x 2	1568	2254	2695

¹ Coefficient of friction μ tot. = 0,14

Tightening torques for screws treated with anti-seizure paste OKS 240¹ (copper paste)

Screw dimension	Tightening torques Nm		
	8.8	10.9	12.9
M16	169	240	287
M16 x 1.5	180	255	307
M18	232	330	392
M18 x 1.5	260	373	444
M20	330	463	557
M20 x 1.5	369	502	620
M22	448	628	754
M22 x 1.5	495	691	847
M24	569	800	960
M24 x 2	624	879	1036
M27	840	1184	1520
M27 X 2	918	1263	1536
M30	1136	1608	1920
M30 x 2	1255	1804	2156
3/4" - 10 UNC	276	388	464
3/4" - 16 UNC	308	432	520

1 Anti-seizure paste (copper paste) is used for the assembly of screw connections, which are exposed to high temperatures and corrosive effects. Prevents seizure and corrosion.

Tightening torques for wheel nuts (fine thread)^{1 2}

Thread diameter	Tightening torques Nm
	10.9
M12x1.5	100
M14x1.5	150
M18x1.5	300 - 350
M20x1.5	400 - 500
M22x1.5	500 - 600

1 Coefficient of friction μ tot. = 0,14

2 These values result in a 90% utilization of the yield point

THANK YOU FOR VISITE WITH

www.repair-manuals.com

DOWNLOAD THIS FULL MANUAL

Until download and place it on your computer We care with you ,We really try our best to complete your orders, so your review is very important to us to improve our services

WE OFFER

ORIGINAL FACTORY MANUALS , WORKSHOP
MANUALS , SERVICE MANUALS , REPAIR

OUR VISION : 100 % CUSTOMER SATISFACTION,
AFTER SALE SERVICE AND KEEP IN TOUCH WITH